

***ENGLISH***

**DDL-900C  
INSTRUCTION MANUAL**

# CONTENTS

|  |           |
|--|-----------|
| <b>1. Specifications</b> .....   | <b>1</b>  |
| 1-1. Head .....  | 1         |
| 1-2. Control box .....   | 1         |
| 1-3. Drawing of table .....  | 2         |
| <b>2. Set-up</b> .....   | <b>3</b>  |
| 2-1. Installation of the sewing machine .....  | 3         |
| 2-2. Installing the thread stand .....   | 4         |
| 2-3. Installing the pedal sensor.....  | 5         |
| 2-4. Installing the knee-lifter.....   | 5         |
| 2-5. Connecting the connector .....  | 6         |
| 2-6. Attaching the connecting rod .....  | 7         |
| 2-7. Pedal pressure and pedal stroke.....  | 7         |
| (1) Adjusting the pressure required to depress the front part of the pedal.....        | 7         |
| (2) Adjusting the pressure required to depress the back part of the pedal.....         | 7         |
| (3) Adjusting the pedal stroke.....  | 7         |
| 2-8. Adjustment of the pedal .....   | 8         |
| (1) Installing the connecting rod.....   | 8         |
| (2) Adjusting the pedal angle .....  | 8         |
| 2-9. Lubrication .....   | 9         |
| 2-10. Connecting the power plug.....   | 10        |
| <b>3. Preparation before sewing</b> .....  | <b>11</b> |
| 3-1. Attaching the needle.....   | 11        |
| 3-2. Setting the bobbin into the bobbin case .....                                     | 11        |
| 3-3. Winding the bobbin thread.....  | 12        |
| 3-4. Threading the machine head .....  | 13        |
| 3-5. Thread tension .....  | 14        |
| (1) Adjusting the needle thread tension.....   | 14        |
| (2) Adjusting the bobbin thread tension .....  | 14        |
| 3-6. Thread take-up spring .....   | 14        |
| (1) Changing the stroke of thread take-up spring.....                                  | 14        |
| (2) Changing the pressure of thread take-up spring .....                               | 14        |
| 3-7. Adjusting the thread take-up stroke.....  | 14        |
| 3-8. Presser foot pressure .....   | 15        |
| 3-9. Hand lifter .....   | 15        |
| 3-10. Adjusting the height of the presser bar .....                                    | 15        |
| 3-11. Adjusting the amount of oil (oil splashes).....                                  | 16        |
| (1) Confirmation of the amount of oil in the hook.....                                 | 16        |
| (2) Adjusting the amount of oil (oil spots) in the hook.....                           | 16        |
| (3) Sample showing the appropriate amount of oil in the hook .....                     | 17        |
| (4) Confirmation of the amount of oil supplied to the face plate parts .....           | 17        |
| (5) Adjusting the amount of oil supplied to the face plate parts .....                 | 17        |
| (6) Sample showing the appropriate amount of oil supplied to the face plate parts..... | 18        |
| 3-12. Needle-to-hook relationship .....  | 19        |
| 3-13. Height of the feed dog .....   | 19        |
| 3-14. Tilt of the feed dog.....  | 20        |
| 3-15. Adjusting the feed timing .....  | 20        |
| 3-16. Checking the knife unit .....  | 21        |

|   |           |
|---|-----------|
| <b>4. For the operator</b> .....  | <b>22</b> |
| <b>4-1. Operating procedure of the sewing machine</b> .....                   | <b>22</b> |
| <b>5. Explanation of the operation panel</b> .....                            | <b>25</b> |
| <b>5-1. Explanation of common buttons</b> .....                               | <b>25</b> |
| (1) Sewing screen.....  | 25        |
| (2) Setting screen .....  | 28        |
| <b>5-2. Explanation of the screen</b> .....                                   | <b>29</b> |
| (1) Free stitch screen .....  | 29        |
| (2) Multi-layer stitch screen.....  | 30        |
| (3) Polygonal-shape stitch screen.....  | 31        |
| (4) Custom pitch stitch screen.....   | 32        |
| (5) Condensation custom selection screen.....                                 | 33        |
| (6) Condensation custom setting screen.....                                   | 34        |
| (7) Reverse feed stitch setting screen for the polygonal-shape stitch.....    | 35        |
| (8) Condensation custom selection screen for the polygonal-shape stitch ..... | 36        |
| (9) Condensation stitch setting screen.....                                   | 37        |
| (10) Screen for setting the number of stitches per inch.....                  | 38        |
| (11) How to use the counter .....   | 40        |
| <b>5-3. Function setting list</b> .....                                       | <b>41</b> |
| (1) User level memory switch.....   | 41        |
| <b>5-4. List of error codes</b> .....   | <b>46</b> |

# 1. Specifications

## 1-1. Head

### DDL-900CS-△

|     |                                   |
|-----|-----------------------------------|
| S : | Light- to medium-weight materials |
| H : | Heavy-weight materials            |

|  | DDL-900CSM   | DDL-900CSH   |
|--|--|--|
| Application                                      | Light- to medium-weight materials  | Heavy-weight materials   |
| Max. sewing speed                                | Stitch length less than 4mm 5,000sti/min<br>Stitch length 4mm or more 4,000sti/min   | 4,000sti/min   |
| Factory-set sewing speed at the time of shipment | 4,000sti/min   | 4,000sti/min   |
| Stitch length                                    | 5mm  | 5mm  |
| Needle bar stroke                                | 30.7±0.5mm   | 36.0±0.5mm   |
| Thread take-up lever stroke                      | Link thread take-up lever<br>106 to 112mm  | Link thread take-up lever<br>110 to 115mm  |
| Needle *1  | DB×1(#14) #11 to 18  | DP×5(#21) #16 to 21  |
| Amount of lift of the presser foot               | Manual: 6 mm, By knee-lifter: 13 mm  | Manual: 6 mm, By knee-lifter: 13 mm  |
| Lubricating oil                                  | JUKI MACHINE Oil(40263283)   |  |
| Noise  | Equivalent continuous emission sound pressure level (L <sub>pA</sub> ) at the workstation: A-weighted value of 81.0 dBA ; (Includes K <sub>pA</sub> = 2.5 dBA) ; according to ISO 10821-C.6.2 -ISO 11204 GR2 at 4,000 sti/min. | Equivalent continuous emission sound pressure level (L <sub>pA</sub> ) at the workstation: A-weighted value of 83.0 dBA ; (Includes K <sub>pA</sub> = 2.5 dBA) ; according to ISO 10821-C.6.2 -ISO 11204 GR2 at 4,000 sti/min. |

**(Caution) Sewing speed differs according to the sewing conditions.**

## 1-2. Control box

|                       |   |
|-----------------------|---|
| Supply voltage        | Single phase 220 to 240V                      |
| Frequency             | 50Hz/60Hz                                     |
| Operating environment | Temperature: 5°C to 35°C, Humidity: 35 to 85% |
| Input                 | 420VA   |
| Motor in use          | Ac servomotor 550 W                           |



## 2. Set-up

### 2-1. Installation of the sewing machine

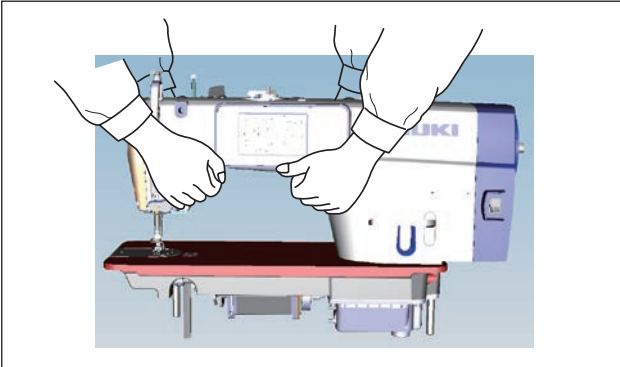

- 1) To prevent possible accidents caused by the full of the sewing machine, perform the work by two persons or more when the machine is moved.



**Never hold the handwheel since it rotates.**

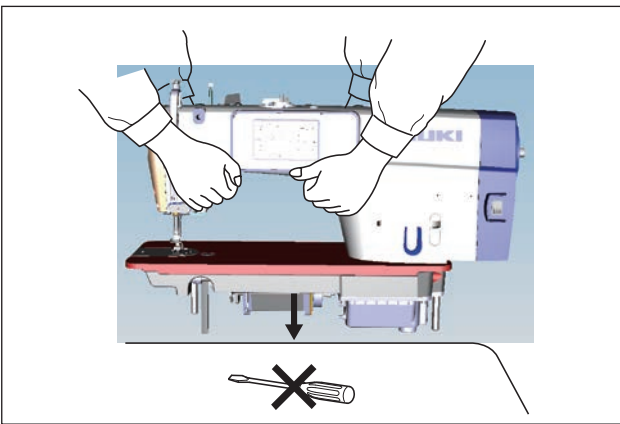

- 2) Place the sewing machine on a horizontal and plane place when placing it and do not place any protruding thing such as a screwdriver or the like.

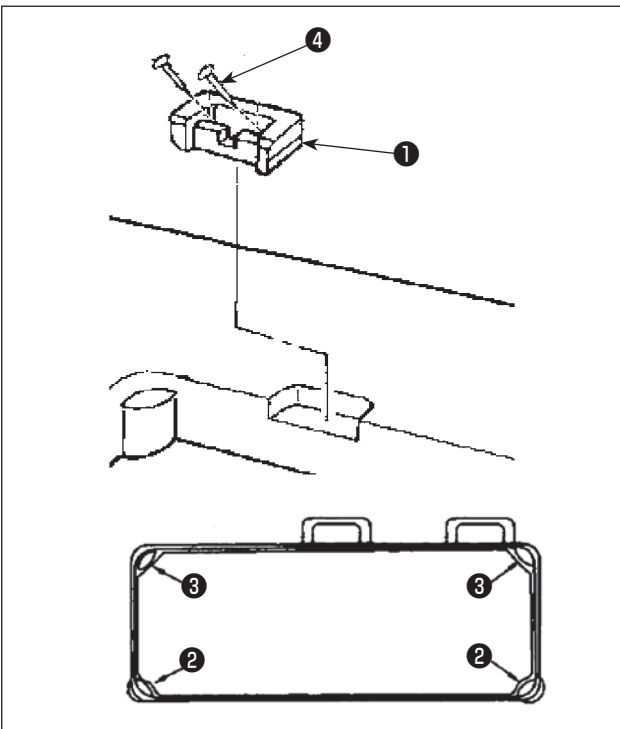

- 3) Place rubber cushions ② and ③ at four corners of the table groove. Secure each of them with nail ④ (one piece).  
(Two types of rubber cushions are provided)
- 4) Secure rubber hinge ① to the table with nails ④ (two pieces) as shown in the figure.

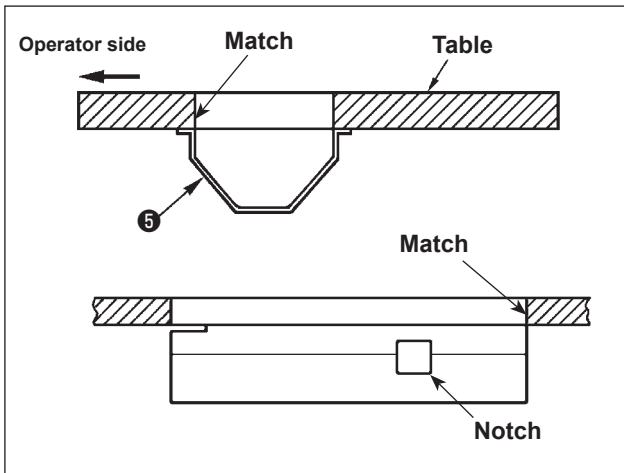

- 5) Attach supplied under-cover ⑤ to the underside of the table with six wood screws.  
(The notch should face the worker.)

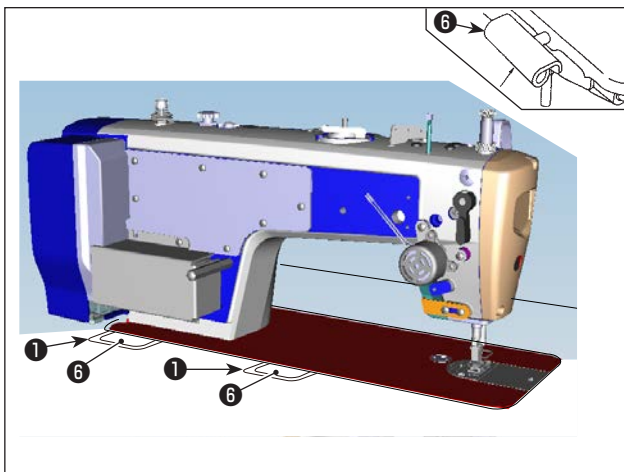

- 6) Put hinge ⑥ into the hole in the bed and engage it with rubber hinge ① of the table. Then, place the machine head on rubber cushions ② and ③ at four corners of the table.

## 2-2. Installing the thread stand

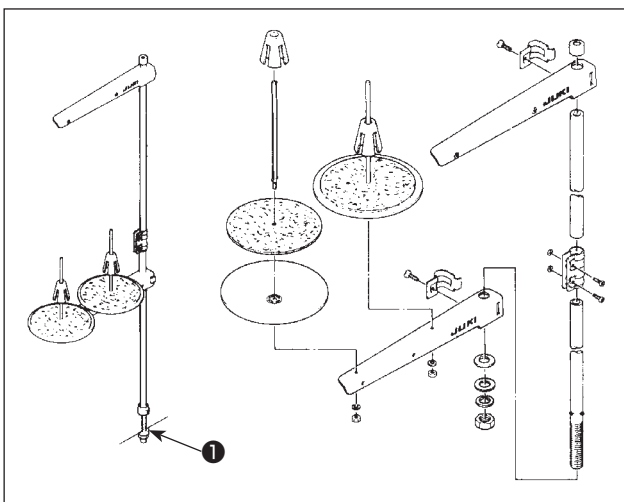

- 1) Assemble the thread stand unit, and insert it in the hole in the machine table.
- 2) Tighten nut ① .

### 2-3. Installing the pedal sensor

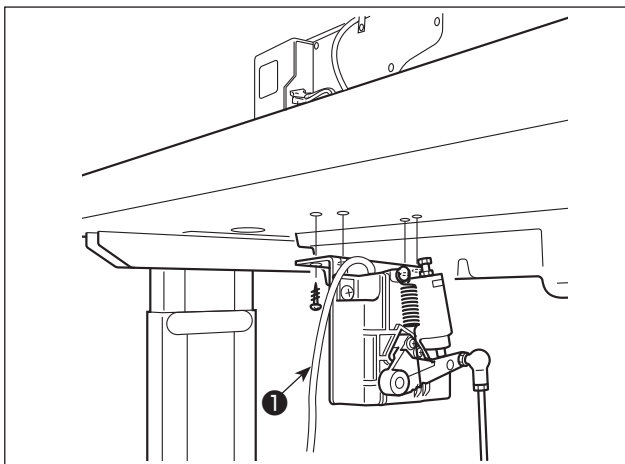

- 1) Install the pedal sensor on the underside of the table with four supplied mounting screws ❶ . It is necessary to install the pedal sensor at such a position that the connecting rod is perpendicular to the table.
- 2) After the completion of installation of the pedal sensor on the table, place the sewing machine head on the table.

### 2-4. Installing the knee-lifter



- 1) Install the knee lifter (asm.) on the underside of the table near the notch on the under-cover with four supplied mounting screws ❶ .

## 2-5. Connecting the connector

### WARNING :



- To protect against personal injury resulting from abrupt start of the sewing machine, be sure to turn the power OFF, unplug the machine and wait for five minutes or more before installing the pedal sensor.
- To prevent damage of device caused by maloperation and wrong specifications, be sure to connect all the corresponding connectors to the specified places. (If any of the connectors is inserted into a wrong connector, not only the device corresponding to the connector can break but also it can start abruptly, inviting the risk of personal injury.)
- To prevent personal injury caused by maloperation, be sure to lock the connector with lock.
- Do not connect the power plug until the connection of cords is completed.
- Fix the cords while taking care not to forcibly bend them or excessively clamp them with staples.
- As for the details of handling respective devices, read carefully the Instruction Manuals supplied with the devices before handling the devices.

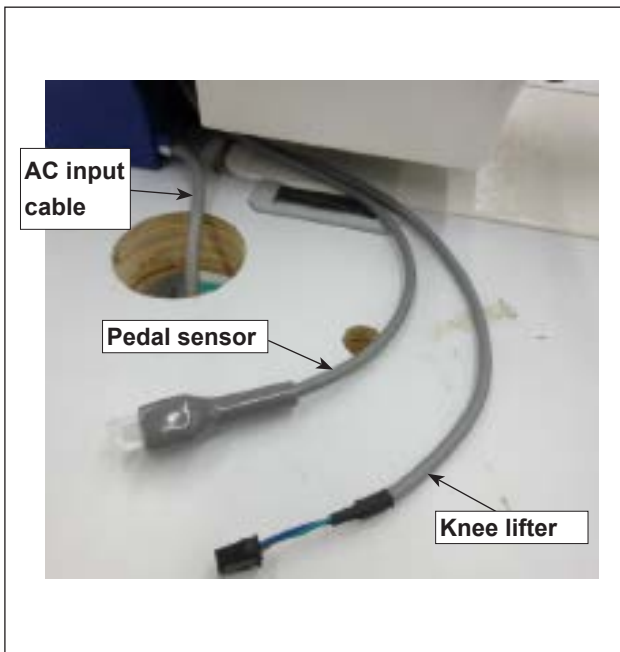

**Do not insert the power plug into the wall outlet.  
Check to be sure that the power switch is turned OFF.**

- 1) Connect three cables after passing them through the hole in the table.



**Be sure to fully insert the connectors into the corresponding ports until they are locked.**

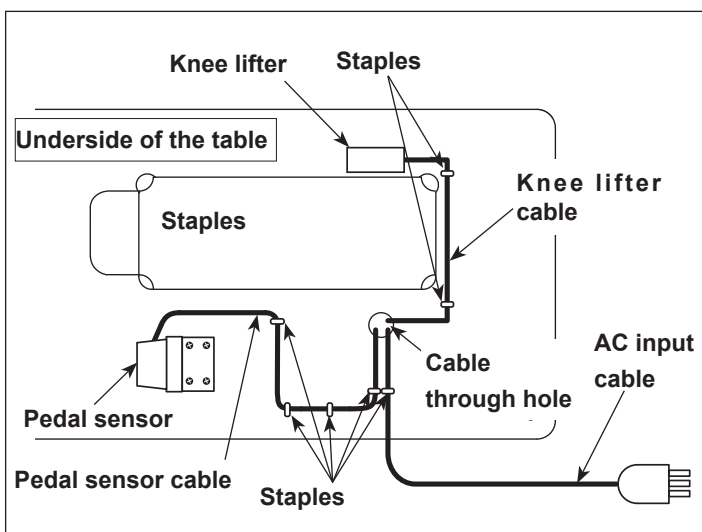

- 2) Secure the pedal cable, AC input cable and knee lifter cable with staples.

## 2-6. Attaching the connecting rod



### WARNING :

To protect against possible personal injury due to abrupt start of the machine, be sure to start the following work after turning the power off and a lapse of 5 minutes or more.

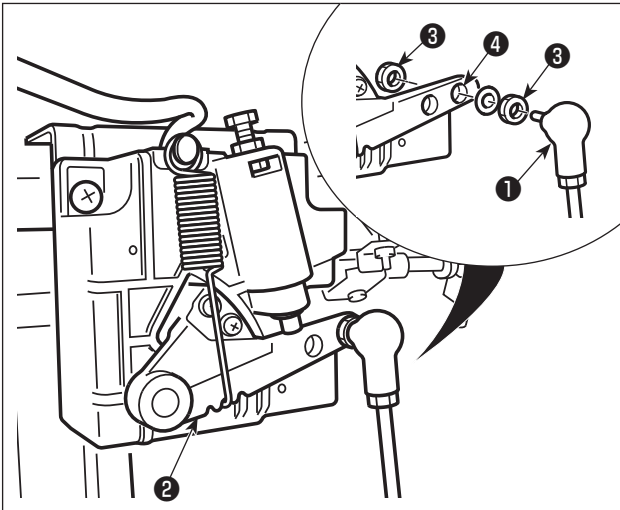

Fix connecting rod ① to installing hole ④ of pedal lever ② with nut ③ .

## 2-7. Pedal pressure and pedal stroke



### WARNING :

Be sure to turn the power OFF before the following work in order to prevent personal injury due to unintentional starting of the sewing machine.

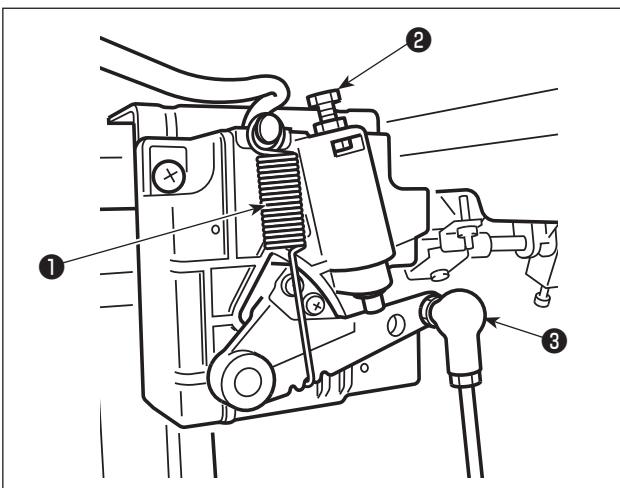

### (1) Adjusting the pressure required to depress the front part of the pedal

- 1) This pressure can be changed by changing the mounting position of pedaling pressure adjust spring ① .
- 2) The pressure decreases when you hook the spring on the left side.
- 3) The pressure increases when you hook the spring on the right side.

### (2) Adjusting the pressure required to depress the back part of the pedal

- 1) This pressure can be adjusted using regulator screw ② .
- 2) The pressure increases as you turn the regulator screw in.
- 3) The pressure decreases as you turn the screw out.

### (3) Adjusting the pedal stroke

- 1) The pedal stroke increases when you insert connecting rod ③ into the right hole.

## 2-8. Adjustment of the pedal



### WARNING :

Be sure to turn the power OFF before the following work in order to prevent personal injury due to unintentional starting of the sewing machine.

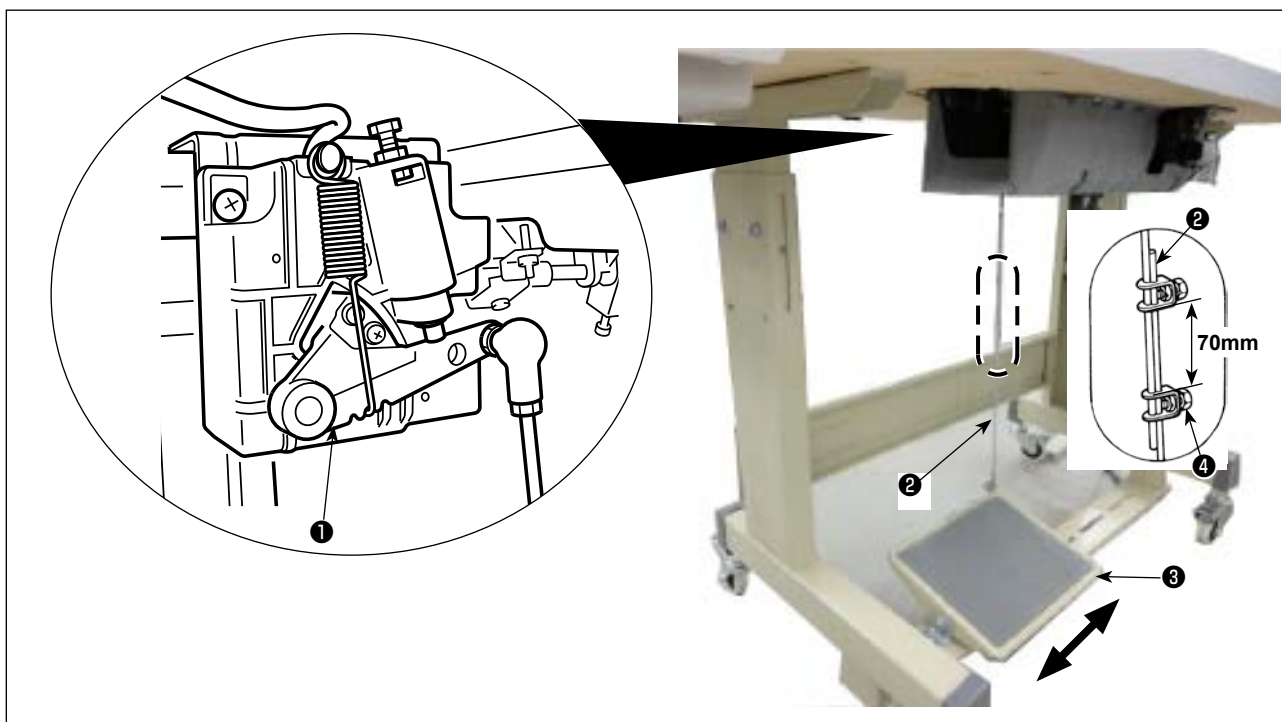

### (1) Installing the connecting rod

- 1) Move pedal **3** to the right or left as illustrated by the arrows so that motor control lever **1** and connecting rod **2** are straightened.

### (2) Adjusting the pedal angle

- 1) The pedal tilt can be freely adjusted by changing the length of the connecting rod **2**.
- 2) Loosen adjust screw **4**, and adjust the length of connecting rod **2**.

## 2-9. Lubrication



### WARNING :

1. Do not connect the power plug until the lubrication has been completed so as to prevent accidents due to abrupt start of the sewing machine,
2. To prevent the occurrence of an inflammation or rash, immediately wash the related portions if oil adheres to your eyes or other parts of your body.
3. If oil is mistakenly swallowed, diarrhea or vomiting may occur. Put oil in a place where children cannot reach.

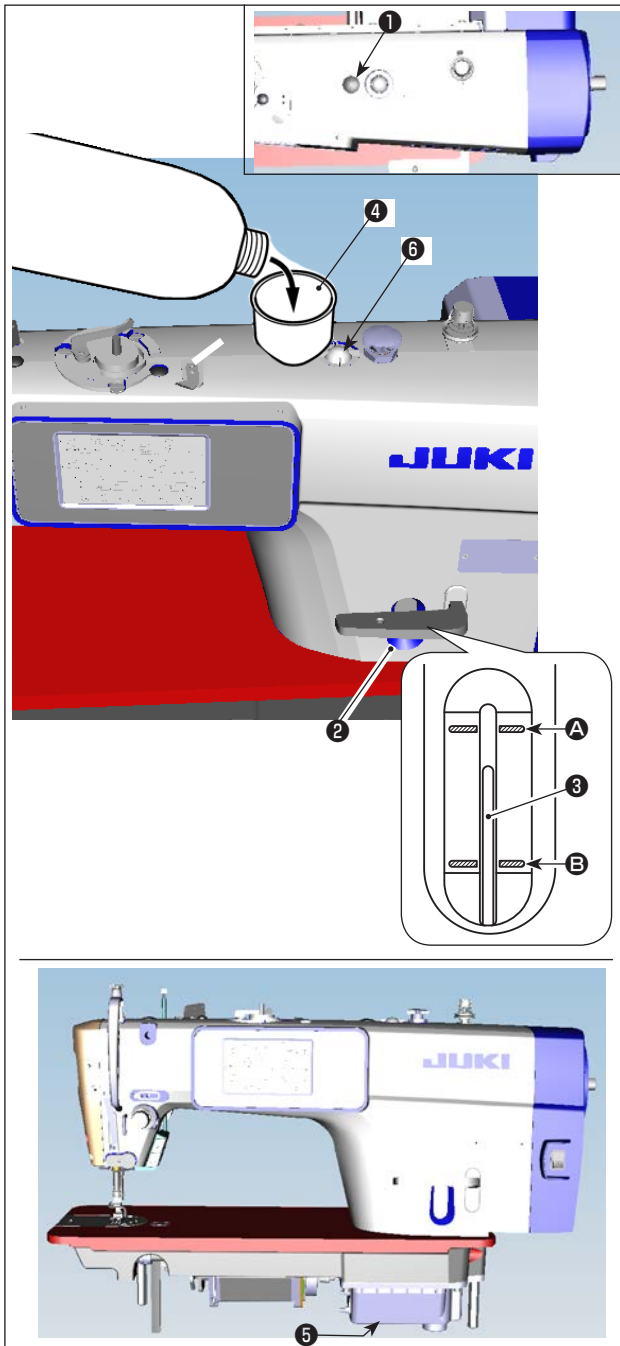

- 1) Before running the sewing machine, remove rubber plug ① from the top of the machine arm, and add oil through the oil inlet using accessory funnel ④ supplied with the sewing machine.
- 2) Fill the oil tank with the oil until the top end of oil amount indicating rod ③ comes between the upper engraved marker line A and the lower engraved marker line B of oil amount indicating window ② .

If the oil is filled excessively, it will lead from the junction between the oil shield and bed, or from the junction between the rubber plug and bed, or proper lubrication will not be performed. So, be careful. In addition, when the oil is vigorously filled, it may overflow from the oil hole. So, be careful.

- \* When oil is added until MAX. line A is reached, the oil quantity becomes 500 cc.
  - \* Check the oil quantity while the sewing machine is at rest.
  - \* Check the quantity of oil in the oil tank by viewing the oil surface from the side of oil amount indicating window ② .
- 3) When you operate the sewing machine, refill oil if the top end of oil amount indicating rod ③ comes down to the lower engraved marker line B of oil amount indicating window ② .
  - 4) When you operate the machine after lubrication, you will see splashing oil through oil sight window ⑥ if the lubrication is adequate.
- \* Note that the amount of the splashing oil is unrelated to the amount of the lubricating oil.

1. When you use a new sewing machine or a sewing machine after an extended period of disuse, use the sewing machine after performing break-in at 2,000 sti/min or less.
2. Purchase JUKI MACHINE Oil (part number: 40263283) as the oil for the sewing machine.
3. Be sure to lubricate clean oil.
4. Be aware that if you add oil to such an extent as to exceed MAX line A, oil may leak from the oil shield mounting plane, bearing, etc., and the frame circulation mechanism may fail to function to cause reverse oil flow, which causes oil leakage from the frame.
5. Transporting the sewing machine with the sewing machine filled with oil can give rise to the risk of oil leakage. Be sure to discharge oil from the sewing machine through drain cock ⑤ .



## 2-10. Connecting the power plug



### **WARNING :**

Be sure to connect the ground wire in order to prevent accidents due to electrical leakage.

- 1) Attach the power plug to the cord. Connect the power plug to the power outlet. Turn OFF the power switch and disconnect the power plug from the power outlet when the sewing machine is not used or when lightening occurs.
- 2) The power plug differs in shape depending on the region and country. When you use this sewing machine in Europe, use the plug that conforms with the relevant applicable standards and regulations in Europe. An expert with electrical knowledge should attach the power plug following the instructions given in the instruction manual for the power plug to be used.
- 3) The picture below shows an example of wiring in the power plug used in Europe and other parts of worlds.

Route the power wires (blue wire) (brown wire) and ground wire (yellow-green wire) in the power plug following the instructions given in the instruction manual for the power plug.



### 3. Preparation before sewing

#### 3-1. Attaching the needle



**WARNING :**

Be sure to turn the power OFF before the following work in order to prevent personal injury due to unintentional starting of the sewing machine.

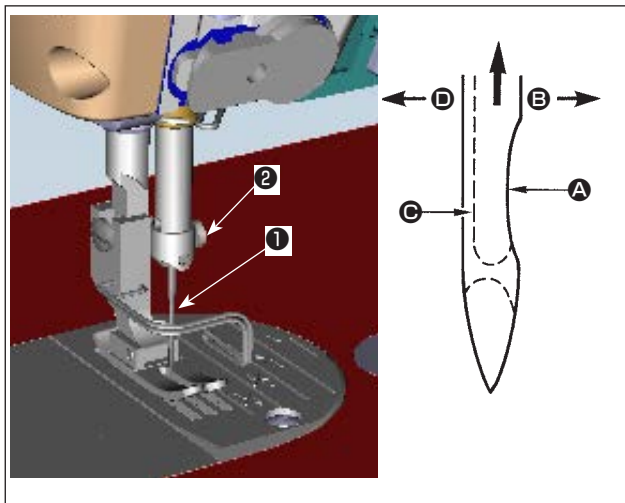

Use the specified needle for the machine. Use the proper needle in accordance with the thickness of thread used and the kinds of the materials.

- 1) Turn the handwheel until the needle bar reaches the highest point of its stroke.
- 2) Loosen screw ②, and hold needle ① with its indented part ① facing exactly to the right in direction ②.
- 3) Insert the needle fully into the hole in the needle bar in the direction of the arrow until the end of hole is reached.
- 4) Securely tighten screw ②.
- 5) Check that long groove ③ of the needle is facing exactly to the left in direction ④.

**When polyester filament thread is used, if the indented part of the needle is tilted toward operator's side, the loop of thread becomes unstable. As a result, hangnail of thread or thread breakage may occur. For the thread that such phenomenon is likely to occur, it is effective to attach the needle with its indented part slightly slanting on the rear side.**



#### 3-2. Setting the bobbin into the bobbin case

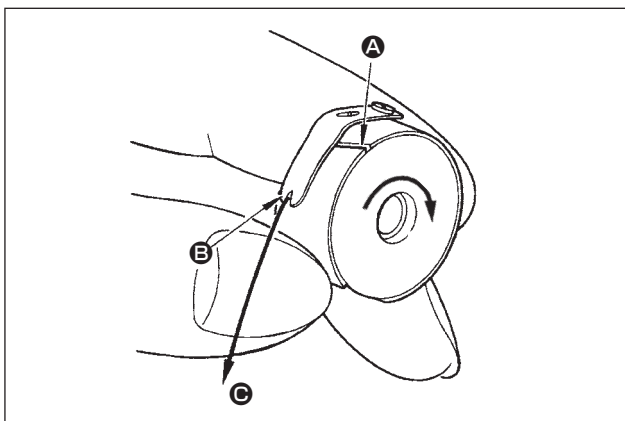

- 1) Pass the thread through thread slit ①, and pull the thread in direction ②. By so doing, the thread will pass under the tension spring and come out from notch ③.
- 2) Check that the bobbin rotates in the direction of the arrow when thread is pulled.

### 3-3. Winding the bobbin thread

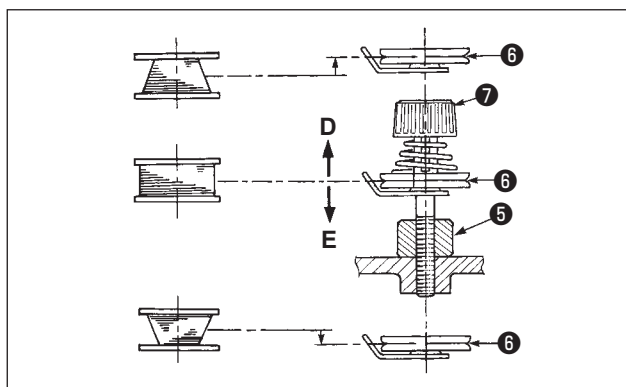
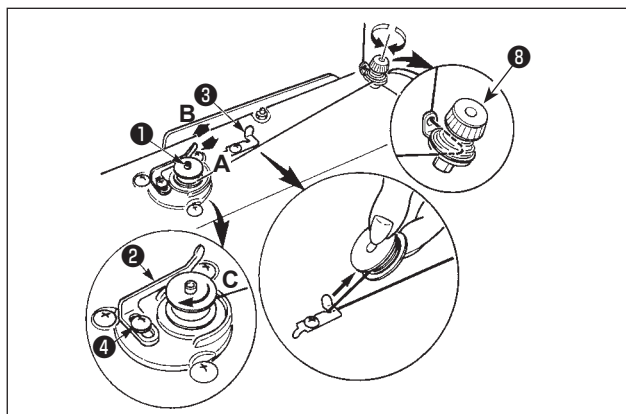

- 1) Insert the bobbin deep into the bobbin winder spindle ① until it will go no further.
- 2) Pass the bobbin thread pulled out from the spool rested on the right side of the thread stand following the order as shown in the figure on the left. Then, wind clockwise the end of the bobbin thread on the bobbin several times.  
(In case of the aluminum bobbin, after winding clockwise the end of the bobbin thread, wind counterclockwise the thread coming from the bobbin thread tension several times to wind the bobbin thread with ease.)
- 3) Press the bobbin winder trip latch ② in the direction of **A** and start the sewing machine. The bobbin rotates in the direction of **C** and the bobbin thread is wound up. The bobbin winder spindle ① automatically as soon as the winding is finished.
- 4) Remove the bobbin and cut the bobbin thread with the thread cut retainer ③ .

- 5) When adjusting the winding amount of the bobbin thread, loosen setscrew ④ and move bobbin winding lever ② to the direction of **A** or **B**. Then tighten setscrew ④ .  
To the direction of **A** : Decrease  
To the direction of **B** : Increase
- 6) In case that the bobbin thread is not wound evenly on the bobbin, loosen screw ⑤ and adjust the height of bobbin thread tension ⑧ .
  - It is the standard that the center of the bobbin is as high as the center of thread tension disk ⑥ .
  - Adjust the position of thread tension disk ⑥ to the direction of **D** when the winding amount of the bobbin thread on the lower part of the bobbin is excessive and to the direction **E** when the winding amount of the bobbin thread on the upper part of the bobbin is excessive.  
After the adjustment, tighten screw ⑤ .
- 7) To adjust the tension of the bobbin winder, turn the thread tension nut ⑦ .



1. When winding the bobbin thread, start the winding in the state that the thread between the bobbin and thread tension disk ⑥ is tense.
2. When winding the bobbin thread in the state that sewing is not performed, remove the needle thread from the thread path of thread take-up and remove the bobbin from the hook.
3. There is the possibility that the thread pulled out from the thread stand is loosened due to the influence (direction) of the wind and may be entangled in the handwheel. Be careful of the direction of the wind.

### 3-4. Threading the machine head



**WARNING :**

Be sure to turn the power OFF before the following work in order to prevent personal injury due to unintentional starting of the sewing machine.

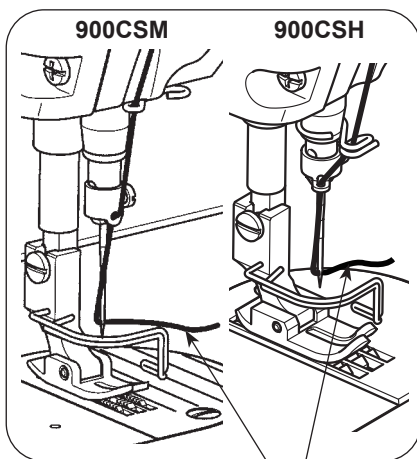

30 to 50mm

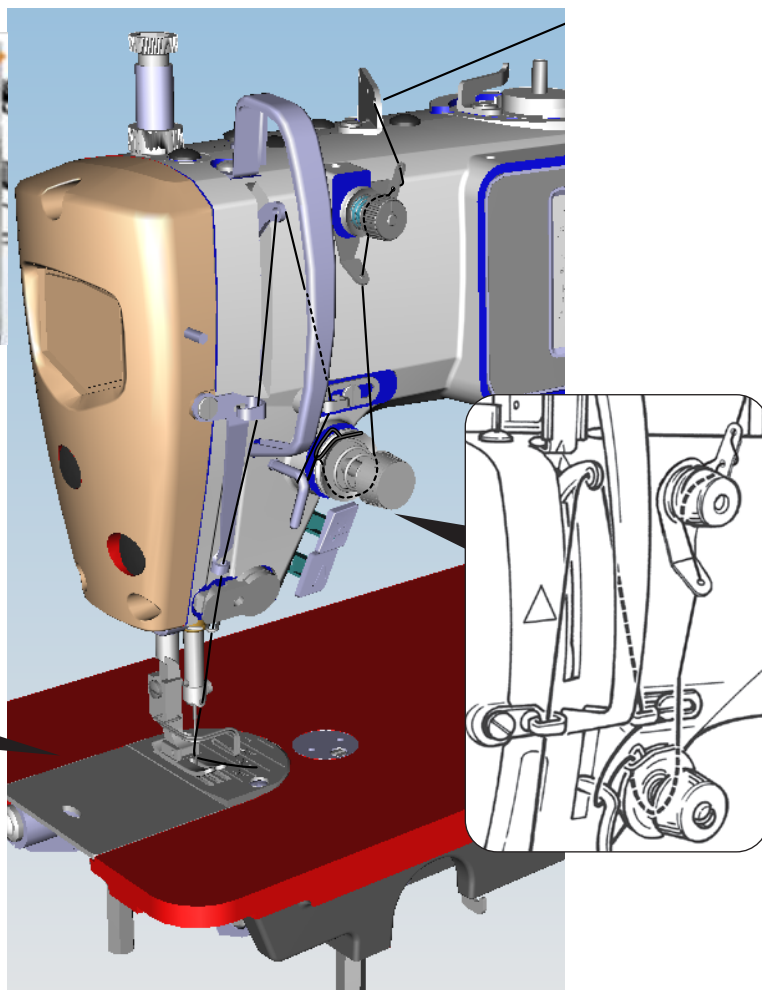

### 3-5. Thread tension

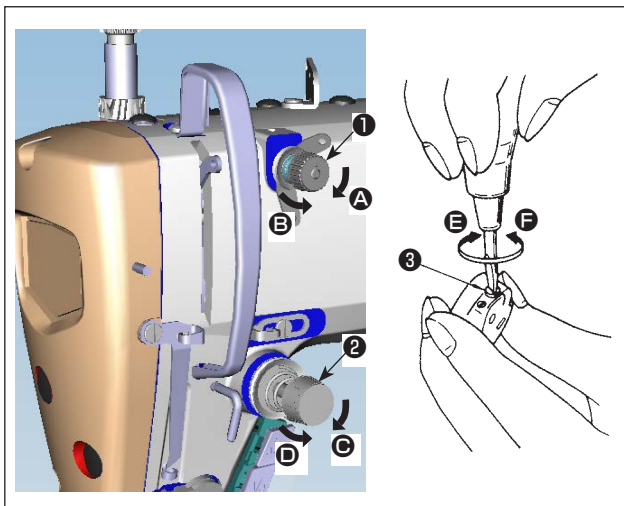

#### (1) Adjusting the needle thread tension

- 1) The length of thread remaining at the needle tip after thread trimming is shortened by turning tension regulating nut No. 1 ① clockwise in direction A.
- 2) It is lengthened by turning the nut counterclockwise in direction B.
- 3) The needle thread tension is increased by turning tension regulating nut No. 2 ② clockwise in direction C.
- 4) It is decreased by turning the nut counterclockwise in direction D.

#### (2) Adjusting the bobbin thread tension

- 1) The bobbin thread tension is increased by turning tension regulating screw ③ clockwise in direction E.
- 2) It is decreased by turning the screw counterclockwise in direction F.

### 3-6. Thread take-up spring

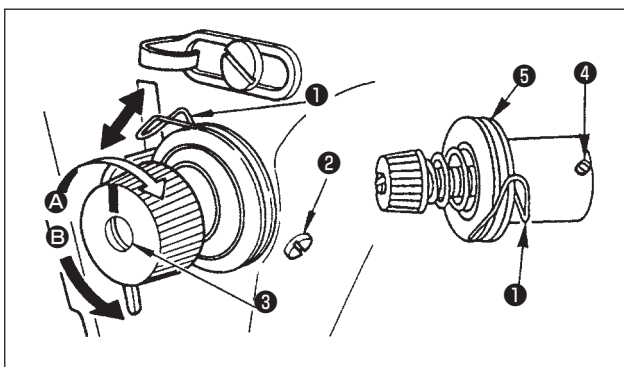

#### (1) Changing the stroke of thread take-up spring

- 1) Loosen setscrew ②.
- 2) As you turn tension post ③ clockwise (in direction A), the stroke of the thread take-up spring will be increased.
- 3) As you turn tension post ③ counterclockwise (in direction B), the stroke will be decreased.

#### (2) Changing the pressure of thread take-up spring

- 1) Loosen setscrew ②, and remove thread tension asm. ⑤.
- 2) Loosen setscrew ④.
- 3) As you turn tension post ③ clockwise (in direction A), the pressure will be increased.
- 4) As you turn the tension post ③ counterclockwise (in direction B), the pressure will be decreased.

**(2) When you have removed thread tension controller (asm.) ⑤ to change the pressure, re-install it to such a position that the tension disk does not float.**

### 3-7. Adjusting the thread take-up stroke



#### WARNING :

Be sure to turn the power OFF before the following work in order to prevent personal injury due to unintentional starting of the sewing machine.

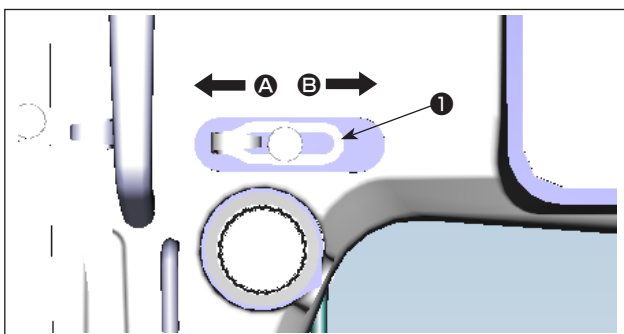

- 1) When sewing heavy-weight materials, move thread guide ① to the left (in direction A) to increase the length of thread pulled out by the thread take-up.
- 2) When sewing light-weight materials, move thread guide ① to the right (in direction B) to decrease the length of thread pulled out by the thread take-up.

### 3-8. Presser foot pressure

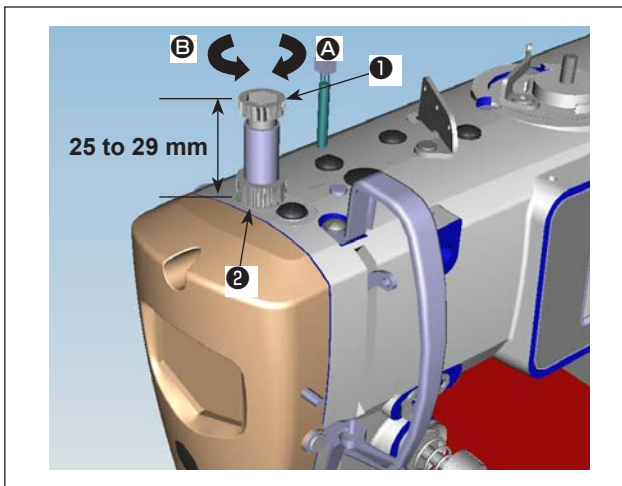

- 1) Loosen nut ② . As you turn presser spring regulator ① clockwise (in direction ①), the presser foot pressure will be increased.
- 2) As you turn the presser spring regulator ① counter-clockwise (in direction ②), the pressure will be decreased.
- 3) After adjustment, tighten nut ② .

The standard value of the pressure regulating thumb screw is 25 to 29 mm.

### 3-9. Hand lifter

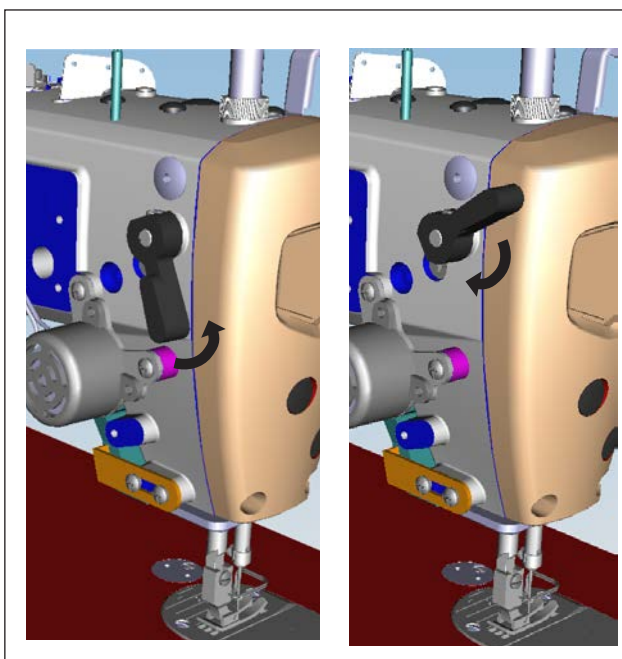

- 1) The presser foot is lifted by moving the lever upward.
- 2) The presser foot is lowered by moving the lever downward.

### 3-10. Adjusting the height of the presser bar



#### WARNING :

Be sure to turn the power OFF before the following work in order to prevent personal injury due to unintentional starting of the sewing machine.

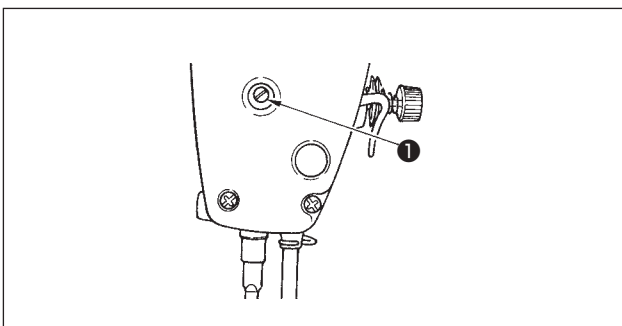

- 1) Loosen setscrew ① , and adjust the presser bar height or the angle of the presser foot.
- 2) After adjustment, securely tighten the setscrew ① .

### 3-11. Adjusting the amount of oil (oil splashes)



#### WARNING :

Be extremely careful about the operation of the machine since the amount of oil has to be checked by turning the hook at a high speed.

#### (1) Confirmation of the amount of oil in the hook

##### ① Amount of oil (oil splashes) confirmation paper

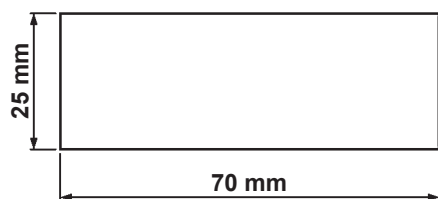

##### ② Position to confirm the amount of oil (oil splashes)

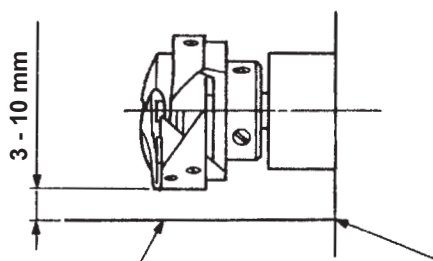

Oil splashes confirmation paper

Closely fit the paper against the wall surface of the bed.

\* When carrying out the procedure described below in 2), remove the slide plate and take extreme caution not to allow your fingers to come in contact with the hook.

- 1) If the machine has not been sufficiently warmed up for operation, make the machine run idle for approximately three minutes. (Moderate intermittent operation)
- 2) Place the amount of oil (oil spots) confirmation paper under the hook immediately after the machine stops running.
- 3) Check to be sure that the oil surface in the oil shield rests in the range between the "MAX. line" and the "MIN. line".
- 4) Confirmation of the amount of oil should be completed in five seconds. (Check the period of time with a watch.)

#### (2) Adjusting the amount of oil (oil spots) in the hook

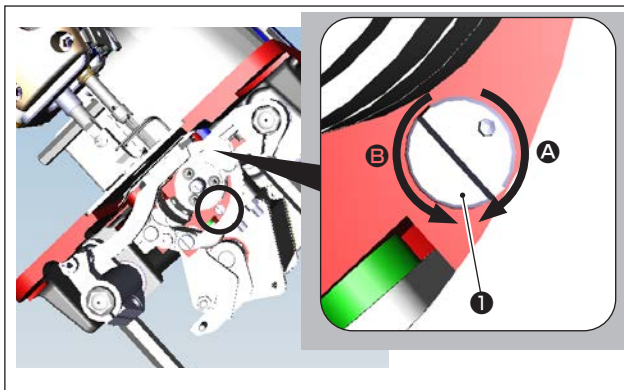

- 1) Tilt the sewing machine. Turn oil amount adjustment screw ❶, which is mounted on the front bushing of lower shaft, in the "+" direction (direction A) to increase the oil amount (oil spots), or in the "-" direction (direction B) to decrease it.

\* The oil-amount +/- indication mark is shown on the underside cover.

- 2) After the amount of oil in the hook has been properly adjusted with the oil amount adjustment screw ❶, make the sewing machine run idle for approximately 30 seconds to check the amount of oil in the hook.

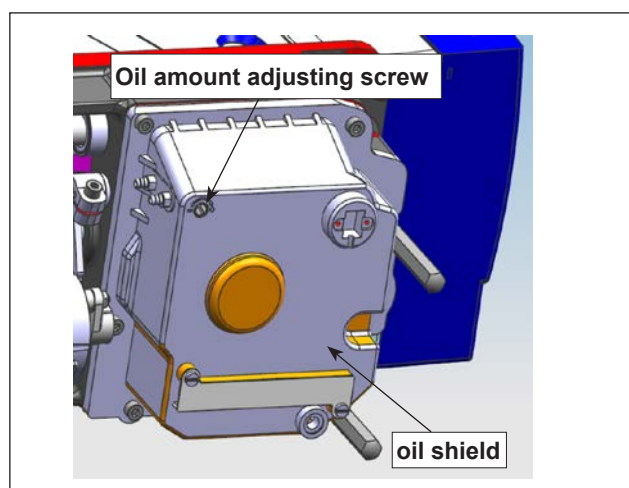

**Do not adjust the oil amount adjusting screw (painted with paint marking) of the oil shield. If you adjust it, the oil amount to the lower shaft may change to cause seizure of the lower shaft.**

### (3) Sample showing the appropriate amount of oil in the hook

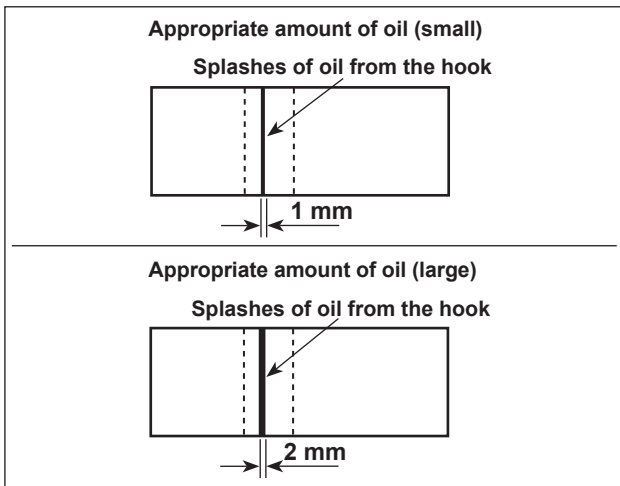

- 1) The amount of oil shown in the samples on the left should be finely adjusted in accordance with sewing processes. Be careful not to excessively increase/decrease the amount of oil in the hook. (If the amount of oil is too small, the hook will be seized (the hook will be hot). If the amount of oil is too much, the sewing product may be stained with oil.)
- 2) Check the oil amount (oil splashes) three times (with three sheets of paper).

### (4) Confirmation of the amount of oil supplied to the face plate parts

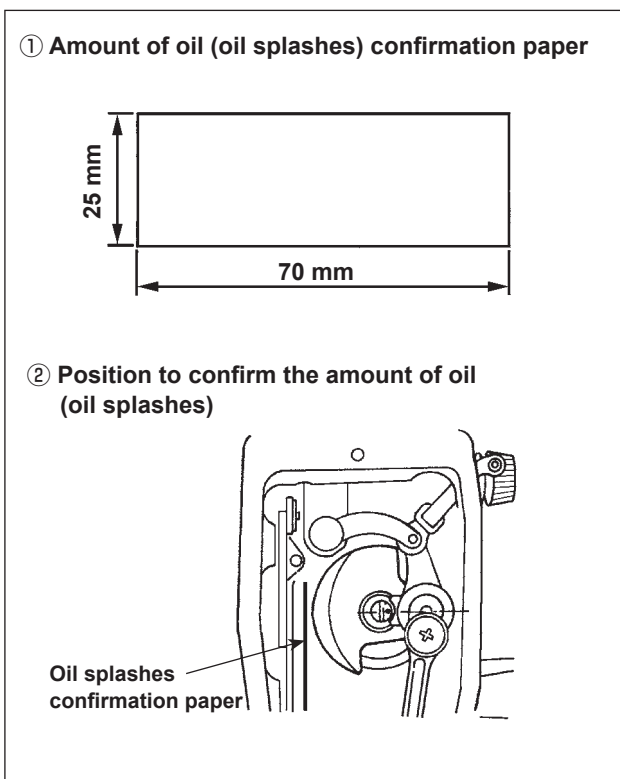

- \* When carrying out the work described below in 2), remove the face plate and take extreme caution not to allow your fingers to come in contact with the thread take-up lever.
- 1) If the machine has not been sufficiently warmed up for operation, make the machine run idle for approximately three minutes. (Moderate intermittent operation)
  - 2) Place the amount of oil (oil spots) confirmation paper under the hook immediately after the machine stops running.
  - 3) Check to be sure that the oil surface in the oil shield rests in the range between the "MAX. line" and the "MIN. line".
  - 4) The time required for the confirmation of the amount of oil (oil splashes) should be completed in ten seconds. (Measure the period of time with a watch.)

### (5) Adjusting the amount of oil supplied to the face plate parts

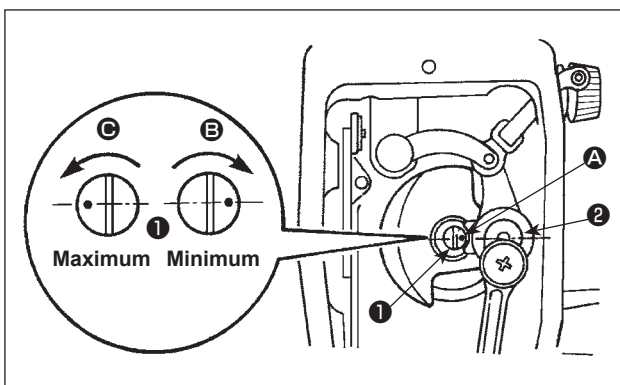

- 1) Adjust the amount of oil supplied to the thread take-up and needle bar crank ② by turning adjust pin ①.
- 2) The minimum amount of oil is reached when marker dot A is brought close to needle bar crank ② by turning the adjust pin in direction B.
- 3) The maximum amount of oil is reached when marker dot A is brought to the position just opposite from the needle bar crank by turning the adjust pin in direction C.

**(6) Sample showing the appropriate amount of oil supplied to the face plate parts**

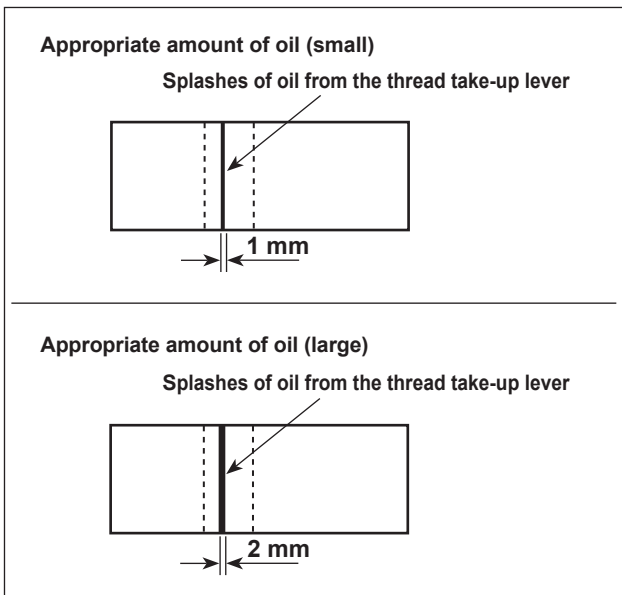

- 1) The state given in the figure shows the appropriate amount of oil (oil splashes). It is necessary to finely adjust the amount of oil in accordance with the sewing processes. However, do not excessively increase/decrease the amount of oil in the hook. (If the amount of oil is too small, the face plate parts will be hot or seize. If the amount of oil is too much, the sewing product may be stained with oil.)
- 2) Check the oil amount (oil splashes) three times (with three sheets of paper).

### 3-12. Needle-to-hook relationship



#### WARNING :

Be sure to turn the power OFF before the following work in order to prevent personal injury due to unintentional starting of the sewing machine.

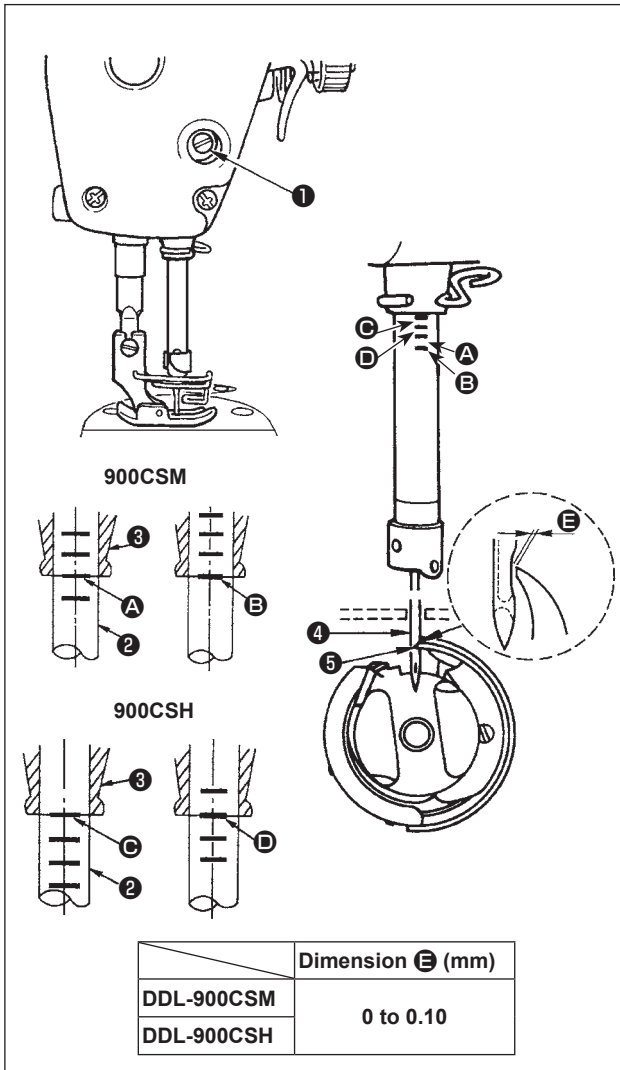

#### Adjust the timing between the needle and the hook as follows :

- 1) Turn the handwheel to bring the needle bar down to the lowest point of its stroke, and loosen setscrew ①.

#### Adjusting the needle bar height.

- 2) [For DDL-900CSM]  
Align marker line A on the needle bar ② with the bottom end of the needle bar lower bushing ③, then tighten clamping screw ① of the needle bar connection.  
[For DDL-900CSH]  
Align marker line C on the needle bar ② with the bottom end of the needle bar lower bushing ③, then tighten clamping screw ① of the needle bar connection.

#### Adjusting position of the hook ⑤.

- 3) [For DDL-900CSM]  
Loosen the three setscrews of the hook, turn the handwheel so as to raise the needle bar ② and align the marker line B with the lower end of the lower bushing of the needle bar ③.  
[For DDL-900CSH]  
Loosen the three setscrews of the hook, turn the handwheel so as to raise the needle bar ② and align the marker line D with the lower end of the lower bushing of the needle bar ③.
- 4) After making the adjustments mentioned in the above steps, align the blade point ⑤ of hook with the center of needle ④. Provide a clearance of dimension E (reference value) between the needle ④ and the hook ⑤, then securely tighten three setscrews of the hook.



If the clearance between the blade point of hook and the needle is smaller than the specified value, the blade point of hook will be damaged. If the clearance is larger, stitch skipping will result.

### 3-13. Height of the feed dog



#### WARNING :

Be sure to turn the power OFF before the following work in order to prevent personal injury due to unintentional starting of the sewing machine.

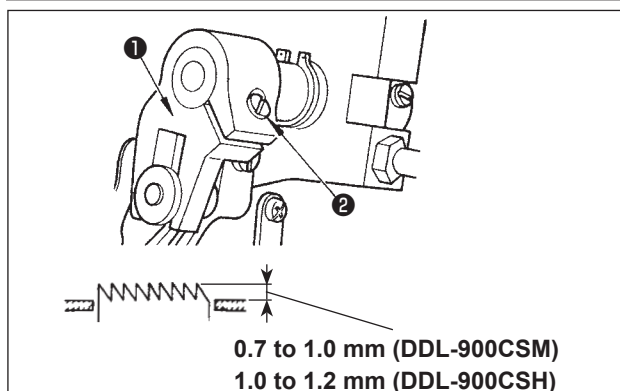

To adjust the height of the feed dog :

- 1) Loosen screw ② of crank ①.
- 2) Move the feed bar up or down to make adjustment.
- 3) Securely tighten screw ②.



If the clamping pressure is insufficient, the motion of the forked portion becomes heavy.

### 3-14. Tilt of the feed dog



#### WARNING :

Be sure to turn the power OFF before the following work in order to prevent personal injury due to unintentional starting of the sewing machine.

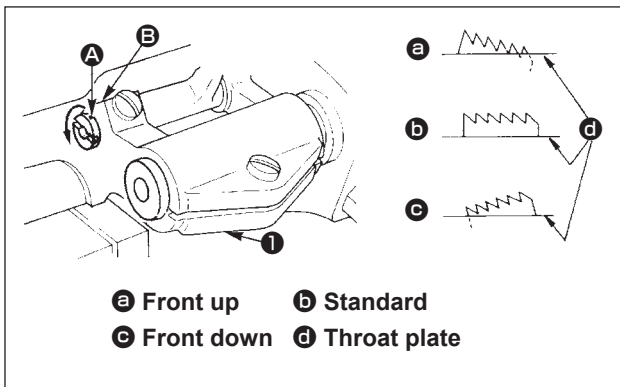

- 1) The standard tilt (horizontal) of the feed dog is obtained when marker dot **A** on the feed bar shaft is aligned with marker dot **B** on feed rocker **1**.
- 2) To tilt the feed dog with its front up in order to prevent puckering, loosen the setscrew, and turn the feed bar shaft 90° in the direction of the arrow, using a screwdriver.
- 3) To tilt the feed dog with its front down in order to prevent uneven material feed, turn the feed bar shaft 90° in the opposite direction from the arrow.



Whenever the feed dog tilt is adjusted, the feed dog height will be changed. So, it is necessary to check the height after tilt adjustment.

### 3-15. Adjusting the feed timing



#### WARNING :

Be sure to turn the power OFF before the following work in order to prevent personal injury due to unintentional starting of the sewing machine.

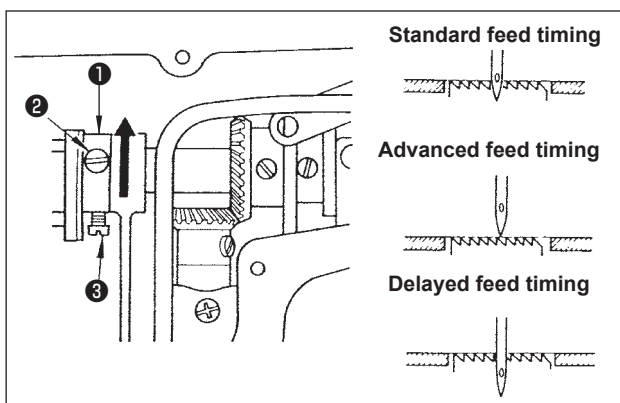

- 1) Loosen screws **2** and **3** in feed eccentric cam **1**, move the feed eccentric cam in the direction of the arrow or opposite direction of the arrow, and firmly tighten the screws.
- 2) If you want to use the standard feed timing, adjust the feed eccentric cam to such a position as to allow the top surface of the feed dog and the lower end of the needle eyelet to align with the top surface of the throat plate when the feed dog comes down below the throat plate.
- 3) To advance the feed timing in order to prevent uneven material feed, move the feed eccentric cam in the direction of the arrow.
- 4) To delay the feed timing in order to increase stitch tightness, move the feed eccentric cam in the opposite direction from the arrow.



Be careful not to move the feed eccentric cam too far, or else needle breakage may result.

### 3-16. Checking the knife unit



**WARNING :**

Turn OFF the power before starting the work so as to prevent accidents caused by abrupt start of the sewing machine.

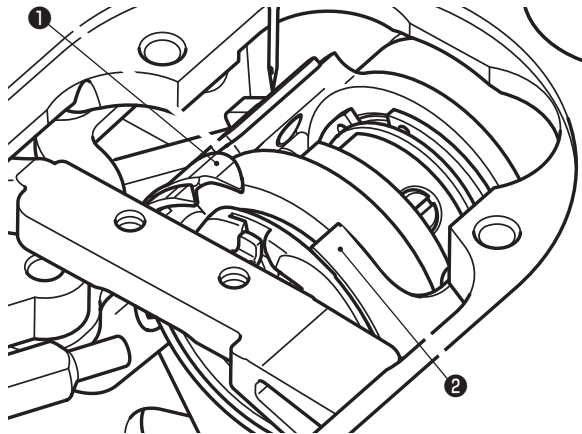

Standby state of the knife

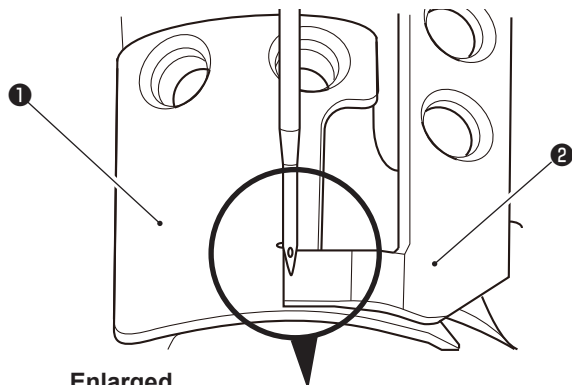
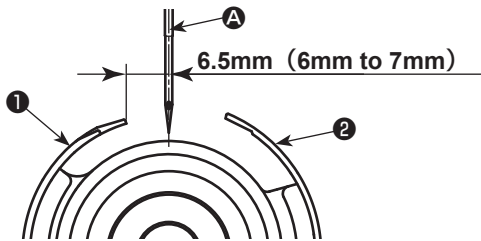

Enlarged detailed view

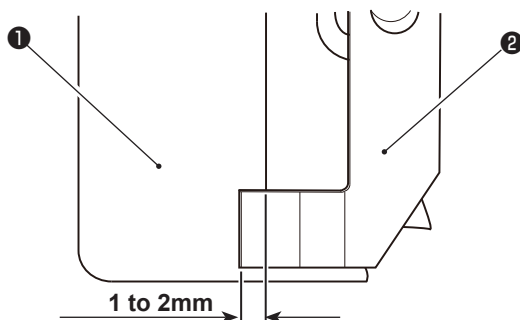
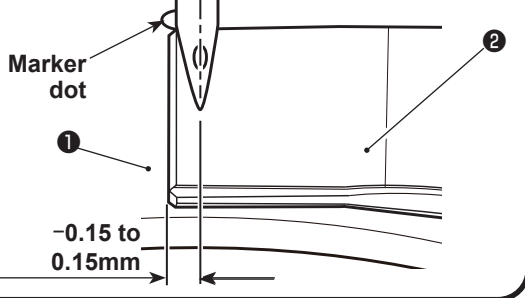

- 1) Check to make sure that the power switch is in the OFF state. Remove the gauge (presser foot, throat plate and feed dog) from around the needle.
- 2) In the standby state of loop spreading knife ①, the distance from the center of needle A to the tip of loop spreading knife ① is 6.5 mm (6 mm to 7 mm).



Be aware that, if the distance between loop spreading knife ① and center of needle A is reduced, thread loop is likely to interfere with loop spreading knife ①.

- 3) With respect to the alignment position of loop spreading knife ① and thread trimming knife ②, the distance from the needle and the tip of thread trimming knife ② is -0.15 to 0.15mm when the marker dot on loop spreading knife is aligned with the tip of thread trimming knife ②.



Be aware that, if the aligning position of the loop spreading knife and the thread trimming knife does not align with center of needle A, the length of thread remaining on the material after thread trimming will be longer.

- 4) The amount of engagement between loop spreading knife ① and thread trimming knife ② is 1 to 2 mm as measured from center of needle A.



Be aware that, if the amount of engagement between them is insufficient, faulty thread trimming can occur.

## 4. For the operator

### 4-1. Operating procedure of the sewing machine

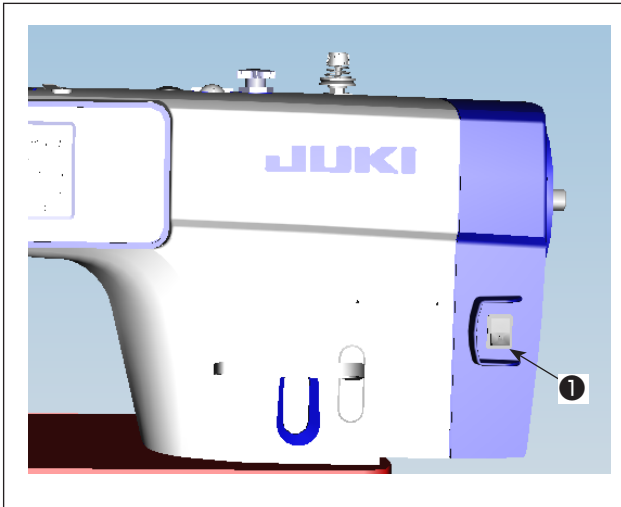

- 1) Turning the power ON with the power switch  
The power to the sewing machine is placed in the ON state when the "I" mark side of power switch ❶ (1ø 220 - 240V type) is pressed; or in the OFF state when the "O" mark side is pressed.

1. Do not strongly tap the power switch by hand.
2. If the power indicator LED on the panel does not light up after having turned ON the power switch, immediately turn OFF the power switch and check the supply voltage.

When you want to re-turn ON power switch after carrying out the aforementioned steps, it is necessary to wait for five minutes or more after you have turned OFF power switch.

3. Do not place your hand or anything under the needle since the needle bar may automatically move according to the memory switch setting when you turn ON the power to the sewing machine.



- 2) When you depress the back part of pedal, the needle bar and the presser lifting motor carry out their initial operation to allow the sewing machine to start sewing.



If you attempt to start sewing without depressing the back part of pedal, the warning message screen will be displayed. To prevent this, be sure to start sewing after depressing the back part of pedal.



**PEDAL** Initial operation not completed

Depress the back part of pedal to perform the initial operation.



**PEDAL** 初始操作未完成

踩下踏板的后部以执行初始操作。

< Origin retrieval screen >

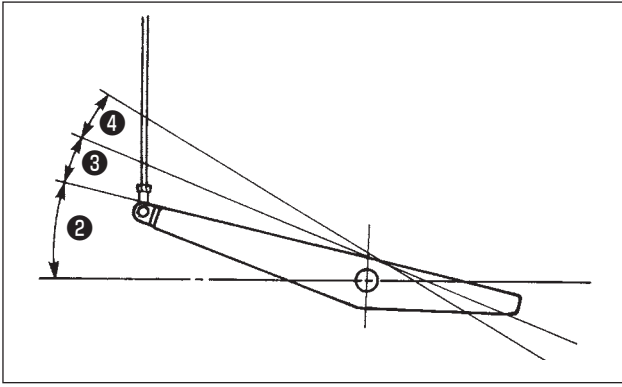

- 3) The pedal is operated in the following four steps.
  - a. The machine runs at low sewing speed when you lightly depress the front part of the pedal ②.
  - b. The machine runs at high sewing speed when you further depress the front part of the pedal ③. (If the automatic reverse feed stitching has been preset, the machine runs at high speed after it completes reverse feed stitching.)
  - c. The machine stops (with its needle up or down) when you reset the pedal to its original position.

d. The machine trims threads when you fully depress the back part of the pedal ④.

\* When the auto-lifer (AK device) is used, one more operating switch is provided between the sewing machine stop switch and thread trimming switch. The presser foot goes up when you lightly depress the back part of the pedal ③, and if you further depress the back part ④, the thread trimmer is actuated.

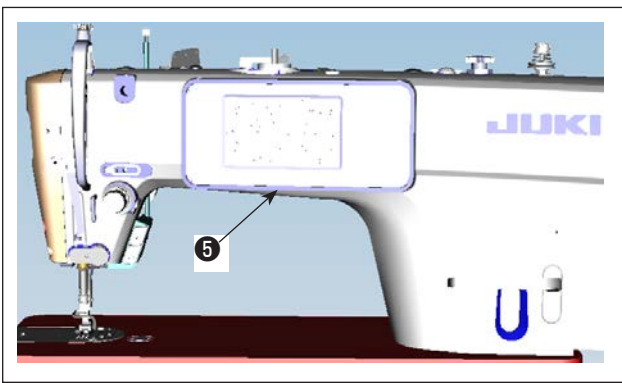

- 4) Reverse feed stitching at the beginning of sewing, reverse feed stitching at the end of sewing and various sewing patterns can be set on built-in panel ⑤ of the machine head.

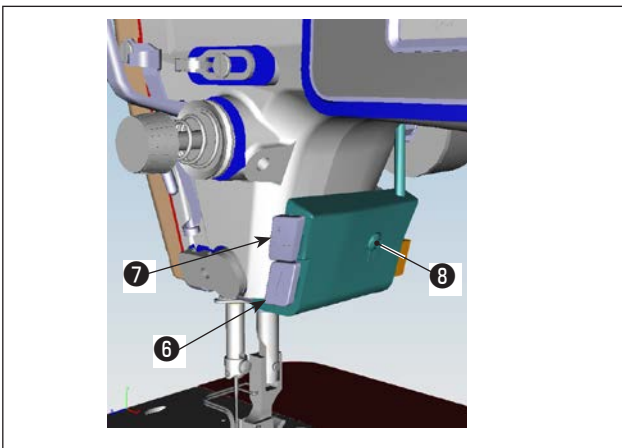

- 5) Press hand switch A ⑥ to carry out reverse feed stitching.  
Function of the hand switch A can be changed with U015 "Hand switch A function setting" (in the initial state, "back tack operation" is selected).  
Press hand switch B ⑦ to carry out continuous needle up/down stitching.  
Function of hand switch B can be changed with U174 "Hand switch B function setting" (in the initial state, "continuous needle up/down stitching" is selected).

Degrees of brightness and OFF-state of the light can be changed over in four stages by pressing switch ⑧ on the side face of the sewing machine.

[Change of intensity]

1 ⇒ 2 ⇒ 3 ⇒ 4 ⇒ 5  
Off ⇒ Bright ⇒ Medium ⇒ Dim ⇒ Off

In this way, every time the switch ⑧ is pressed, the hand lamp status is changed in repetition.

- 6) After the completion of sewing, check to make sure that the sewing machine has stopped.

Then, press power switch ① to turn it OFF.

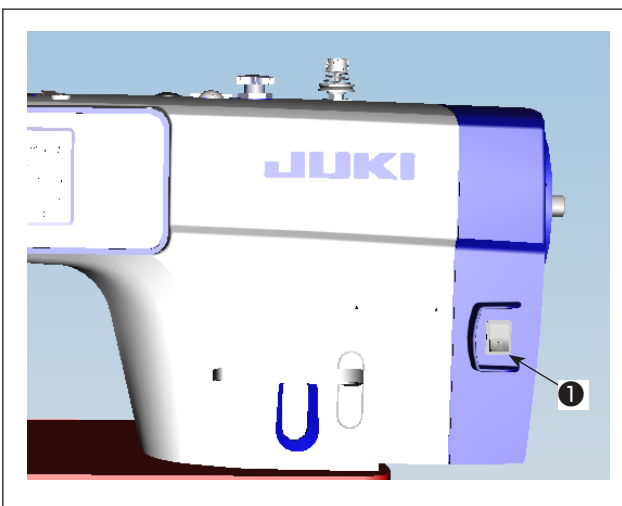

**Caution**  
In the case the machine is not used for a long time, remove the power plug from the plug receptacle.

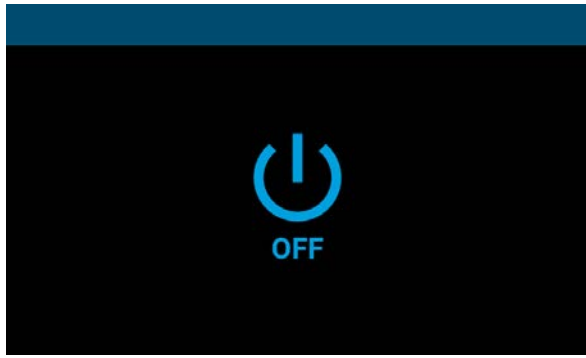

<Power OFF processing screen>

- 7) When you turn OFF the power switch, the "Power OFF processing screen" is displayed. When the power is turned OFF completely, the screen display disappears.



While the "Power OFF processing screen" is displayed, do not turn ON the power switch. If you turn ON the power switch during power OFF processing, the caution screen will be displayed as shown below. When you have turned OFF the power switch, re-turn it ON after confirming that the screen display disappears.

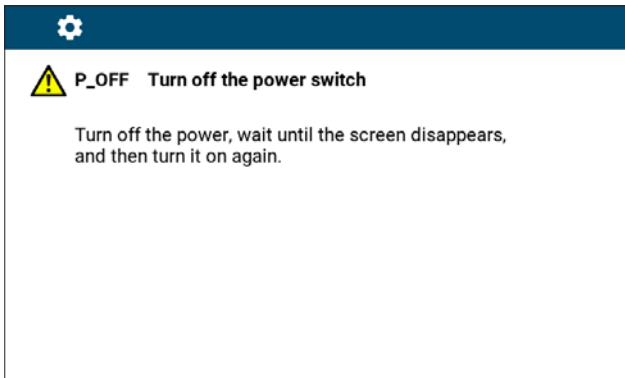

<Power OFF confirmation screen>







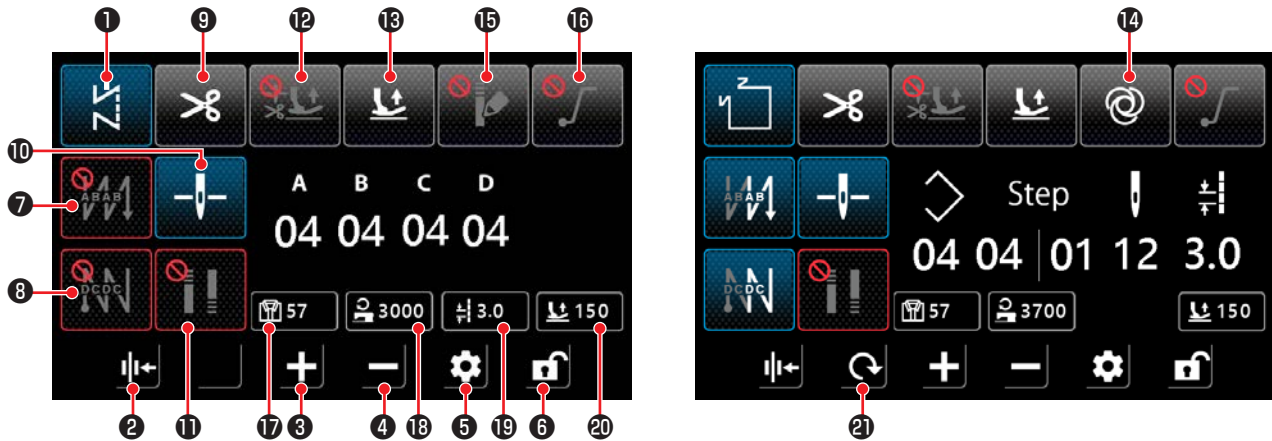















## 5. Explanation of the operation panel











### 5-1. Explanation of common buttons

#### (1) Sewing screen











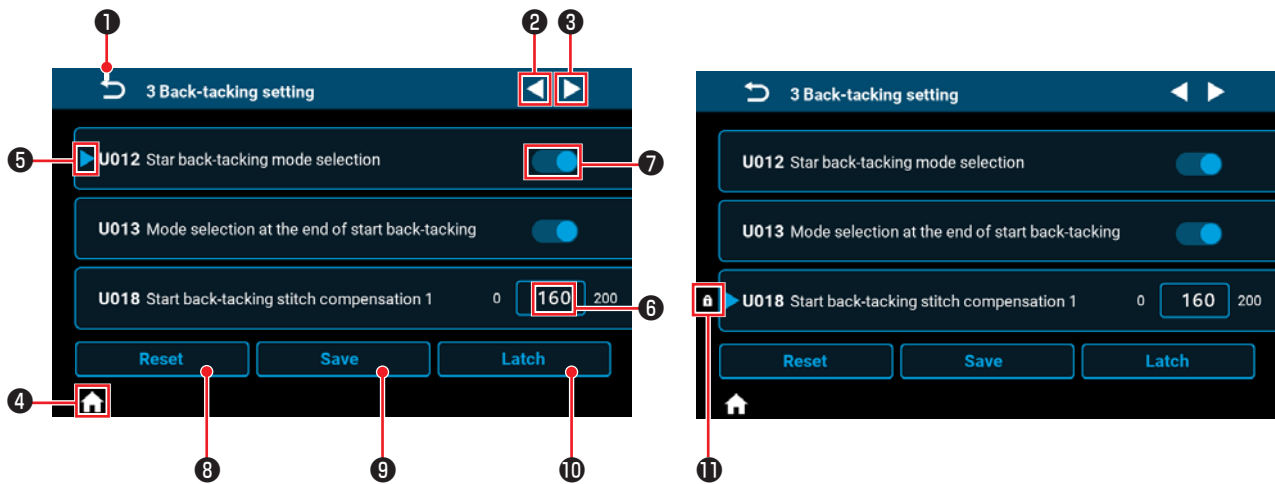



| No. | Name                                     | Display   |
|-----|--|---|
| ①   | Mode changeover key                      | <p>This key is used to display the current sewing mode. Every time you press this key, the sewing mode is changed over in the order of free stitch, multi-layer stitch, polygonal-shape stitch and custom pitch stitch.</p> <p>: Free stitch      : Multi-layer stitch      : Polygonal-shape stitch      : Custom pitch stitch</p> |
| ②   | Thread presser setting                   | <p>This key is used to change over the thread presser function between ON and OFF.</p> : ON       : OFF   |
| ③   | Parameter increase key                   | The parameter can be increased by one by clicking this key. The parameter can be increased continuously by holding down this key.   |
| ④   | Parameter decrease key                   | The parameter can be decreased by one by clicking this key. The parameter can be decreased continuously by holding down this key.   |
| ⑤   | Setting key                              | This key is used to display the parameter setting screen.   |
| ⑥   | Lock screen key                          | <p>This key is used to change over the screen lock status.</p> : Locked       : Unlocked  |
| ⑦   | Sewing-start reverse feed stitch setting | <p>This button is used to change over the sewing-start reverse feed stitch pattern in sequence.</p> : OFF       : Process B<br>: Process A → Process B       : Process A → Process B → Process A → Process B<br><p>The reverse feed stitch setting screen is displayed by holding down this button.</p>                             |

| No. | Name  | Display   |
|-----|---|---|
| 8   | Sewing-end reverse feed stitch setting                            | <p>This button is used to change over the sewing-end reverse feed stitch pattern in sequence.</p>  : OFF  : Process C<br> : Process C → Process D  : Process C → Process D → Process C → Process D<br>The reverse feed stitch setting screen is displayed by holding down this button.  |
| 9   | Thread trimming setting   | <p>This button is used to change over the thread trimming function between ON and OFF.</p>  : ON  : OFF   |
| 10  | Needle bar stop position  | <p>This button is used to change over the needle bar stop position when the sewing machine stops in the middle of sewing.</p>  : Lower stop  : Upper stop<br>* This setting does not change the operation for a multi-layer stitching pattern.  |
| 11  | Condensation stitch setting                                       | <p>This button is used to change over the condensation stitch setting in sequence.</p>  : Condensation stitch OFF  : Sewing-start condensation stitch ON<br> : Sewing-end condensation stitch ON  : Sewing-start/ending condensation stitch ON<br>* Carry out setting of the condensation stitch in "2 Tight seam function setting" on the setting screen. The condensation stitch setting screen is displayed by holding down this button.<br>* When the thread trimming is set to "OFF", the sewing-end condensation stitch is not carried out. |
| 12  | Automatic presser lifting function setting                        | <p>This button is used to set the automatic presser lifting function after a stop in the middle of sewing and after thread trimming.</p>  : Function is disabled  : Automatic presser lifting after stop in the middle is enabled.<br> : Automatic presser lifting after thread trimming is enabled  : Automatic presser lifting after a temporary stop and after thread trimming is enabled.<br>* Auto-lifter does not operate after a stop in the middle of sewing for a multi-layer stitching pattern.                                 |
| 13  | Presser lifting function by depressing the back part of the pedal | <p>This button is used to change over the presser lifting function by depressing the back part of the pedal between ON and OFF.</p>  : ON  : OFF  |
| 14  | One shot function   | <p>This button is used to change over the one shot function between ON and OFF.</p>  : ON  : OFF  |
| 15  | Condensation custom pattern function                              | <p>This button is used to change over the condensation custom pattern between ON and OFF.</p> <p>When the function is ON, the condensation custom setting screen is displayed.</p>  : ON  : OFF   |

| No. | Name                                | Display   |
|-----|-------------------------------------|---|
| 16  | Soft-start function setting         | <p>This button is used to change over the soft-start function between ON and OFF.</p> <p> : ON       : OFF</p>  |
| 17  | Sewing count display                | <p> The sewing count value is displayed.<br/>The count is cleared by double-clicking this button.</p>  |
| 18  | Sewing speed display                | <p> The current sewing speed is displayed.<br/>The data is put into the selected state () by clicking this button, and can be changed with the parameter increase/decrease key.</p>                           |
| 19  | Stitch length display               | <p> The stitch length under the current mode is displayed.<br/>The data is put into the selected state () by clicking this button, and can be changed with the parameter increase/decrease key.</p>           |
| 20  | Presser foot lifting height display | <p> The presser foot lifting height under the current mode is displayed. The data is put into the selected state () by clicking this button, and can be changed with the parameter increase/decrease key.</p> |
| 21  | Screen change-over key              | <p>This key is used to change over the screen.</p> <p></p>   |

## (2) Setting screen

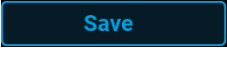

| No. | Item   | Explanation  |
|-----|--|--|
| ①   |   | This item is used to return the screen to the previous screen.   |
| ②   |   | This item is used to move the page forward.  |
| ③   |   | This item is used to move the page backward.   |
| ④   |   | This item is used to return the screen to the sewing screen.   |
| ⑤   |   | This item is displayed for the parameter that is being selected.<br>The parameter is put into the selected state by clicking within the parameter frame.                                 |
| ⑥   |   | Set value of the parameter is displayed.<br>The numeric keypad screen for inputting the parameter is displayed by clicking within the parameter frame.                                   |
| ⑦   | <br> : OFF,  : ON | ON or OFF state of the function is displayed. The ON/OFF state of the function is changed over by clicking this item.  |
| ⑧   |   | This item is used to return the setting of the parameter selected with ⑤ to the initial value.   |
| ⑨   |   | This item is used to confirm the parameter setting you have changed.<br><b>*If you exit the screen without confirming the setting, the content you have changed will not be saved.</b>   |
| ⑩   |   | When this button is held down, the setting of the parameter selected with ⑤ is fixed or released from fixed state.   |
| ⑪   |   | This item is displayed for the parameter setting of which is fixed.<br>If you reset the parameter setting of which is fixed, the parameter will be reset to the value when it was fixed. |

## 5-2. Explanation of the screen

### (1) Free stitch screen

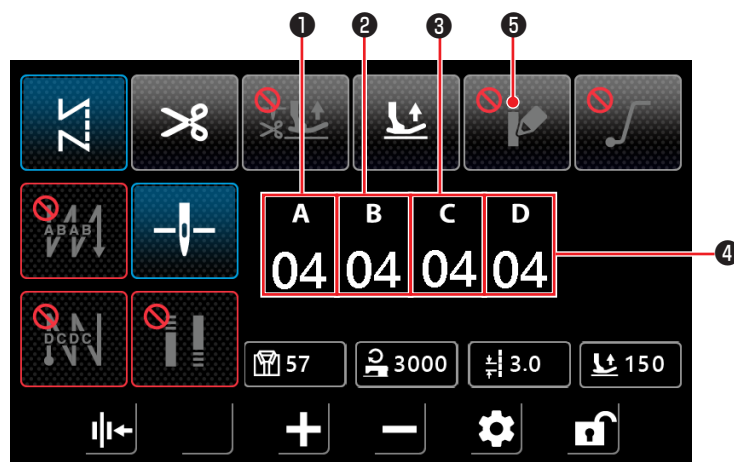

| No. | Item  | Range | Initial value | Explanation   |
|-----|---|-------|---------------|---|
| ①   | <b>A</b><br>04  | 0-15  | 4             | The number of stitches for the sewing-start reverse feed stitching process A is displayed.<br>The numeric keypad screen for inputting the number of stitches is displayed by clicking the numeric part. |
| ②   | <b>B</b><br>04  | 0-15  | 4             | The number of stitches for the sewing-start reverse feed stitching process B is displayed.<br>The numeric keypad screen for inputting the number of stitches is displayed by clicking the numeric part. |
| ③   | <b>C</b><br>04  | 0-15  | 4             | The number of stitches for the sewing-end reverse feed stitching process C is displayed.<br>The numeric keypad screen for inputting the number of stitches is displayed by clicking the numeric part.   |
| ④   | <b>D</b><br>04  | 0-15  | 4             | The number of stitches for the sewing-end reverse feed stitching process D is displayed.<br>The numeric keypad screen for inputting the number of stitches is displayed by clicking the numeric part.   |
| ⑤   |  |       |               | The condensation custom is placed in ON and the <b>"(5) Condensation custom selection screen"</b> p.33 is displayed by clicking this item.  |

\* Be aware that the sewing machine starts when you depress the pedal even when the numeric keypad is displayed on the screen.

## (2) Multi-layer stitch screen

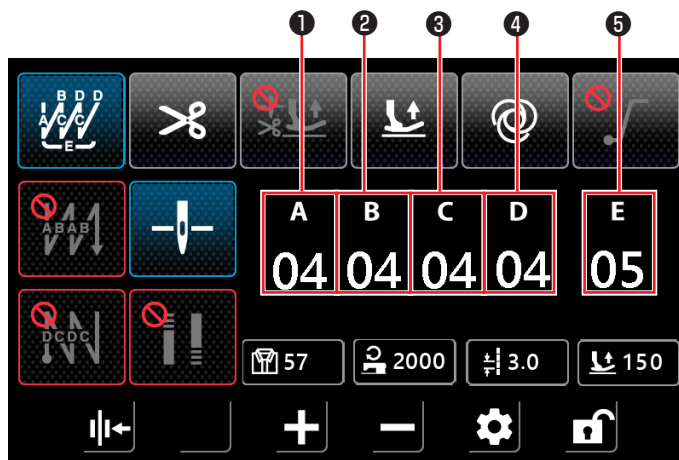



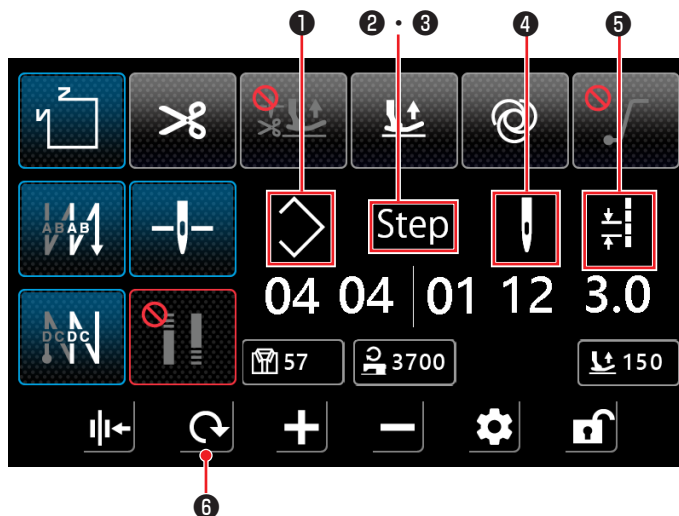

| No. | Item           | Range | Initial value | Explanation   |
|-----|----------------|-------|---------------|---|
| ①   | <b>A</b><br>04 | 0-15  | 4             | The number of stitches for process A is displayed.<br>The numeric keypad screen for inputting the number of stitches is displayed by clicking the numeric part. |
| ②   | <b>B</b><br>04 | 0-15  | 4             | The number of stitches for process B is displayed.<br>The numeric keypad screen for inputting the number of stitches is displayed by clicking the numeric part. |
| ③   | <b>C</b><br>04 | 0-15  | 4             | The number of stitches for process C is displayed.<br>The numeric keypad screen for inputting the number of stitches is displayed by clicking the numeric part. |
| ④   | <b>D</b><br>04 | 0-15  | 4             | The number of stitches for process D is displayed.<br>The numeric keypad screen for inputting the number of stitches is displayed by clicking the numeric part. |
| ⑤   | <b>E</b><br>05 | 0-15  | 5             | The number of repetitions is displayed.<br>The screen for inputting the number of repetitions is displayed by clicking the numeric part.                        |

\* Be aware that the sewing machine starts when you depress the pedal even when the numeric keypad is displayed on the screen.

### (3) Polygonal-shape stitch screen





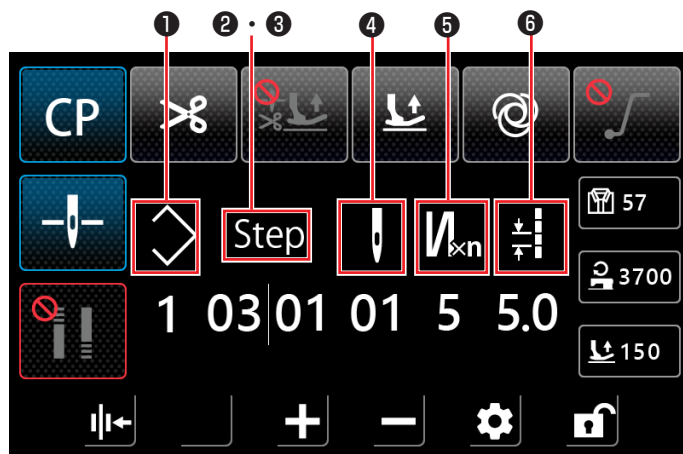

| No. | Item  | Range | Explanation   |
|-----|---|-------|---|
| ①   |   | 1-10  | Polygonal-shape stitching pattern number is displayed.<br>The numeric keypad screen for inputting the pattern number is displayed by clicking the numeric part.   |
| ②・③ |  | 1-15  | Number ② on the left indicates the total number of steps of the pattern.<br>The numeric keypad screen for inputting the total number of steps is displayed by clicking the numeric part.<br>Number ③ on the right indicates the step number for editing. The numeric keypad screen for inputting the step number is displayed by clicking the numeric part. |
| ④   |  | 0-99  | The number of stitches of the step that is being edited is displayed.<br>The numeric keypad screen for inputting the number of stitches is displayed by clicking the numeric part.<br>If the number of stitches is 0 (zero), the sewing machine will finish sewing at the previous step. The number of stitches for step 1 cannot be set to 0 (zero).       |
| ⑤   |  | 0-5.0 | Stitch length<br>The stitch length for the step that is being edited is displayed.<br>The numeric keypad screen for inputting the stitch length is displayed by clicking the numeric part.  |
| ⑥   |  |       | In the case the condensation custom is placed in OFF, the " <b>(7) Reverse feed stitch setting screen for the polygonal-shape stitch</b> "p.35 is displayed.<br>In the case the condensation custom is placed in ON, the " <b>(8) Condensation custom selection screen for the polygonal-shape stitch</b> "p.36 is displayed.                               |

\* Be aware that the sewing machine starts when you depress the pedal even when the numeric keypad is displayed on the screen.

#### (4) Custom pitch stitch screen







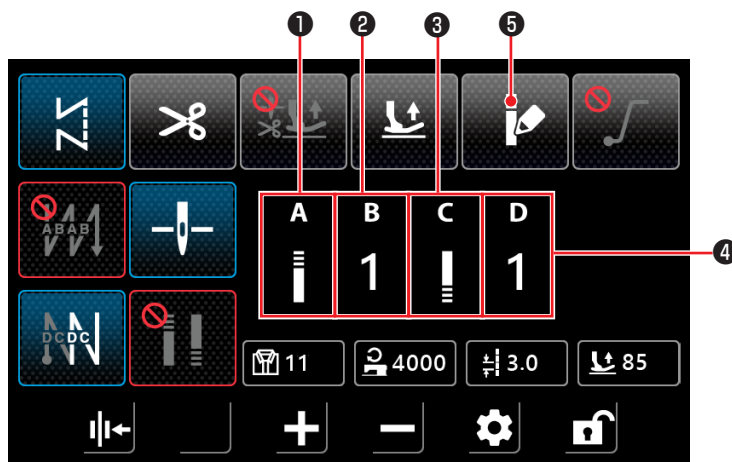

| No.   | Item  | Range | Explanation   |
|-------|---|-------|---|
| ①     |    | 1-9   | The custom pitch pattern number is displayed.<br>The numeric keypad screen for inputting the pattern number is displayed by clicking the numeric part.  |
| ② · ③ |  | 1-10  | Number ② on the left indicates the total number of steps of the pattern.<br>The numeric keypad screen for inputting the total number of steps is displayed by clicking the numeric part.<br>Number ③ on the right indicates the step number for editing. The numeric keypad screen for inputting the step number is displayed by clicking the numeric part.   |
| ④     |  | 1-99  | The number of stitches of the step that is being edited is displayed.<br>In the case the number of times of forward and reverse feed stitching for the multi-layer stitch is 1, the number represents the number of stitches for the step. In the case the number of times of forward and reverse feed stitching for the multi-layer stitch is larger than 1, the number represents the number of times to repeat multi-layer stitching.<br>The numeric keypad screen for inputting the number of stitches is displayed by clicking the numeric part.                 |
| ⑤     |  | 1-9   | Number of times of forward and reverse feed stitching for the multi-layer stitch<br>The number of times of forward and reverse stitching for the multi-layer stitch for the step that is being edited is displayed. In the case the value is 1, the sewing machine does not perform multi-layer stitching and the value represents the number of stitches for the step.<br>The numeric keypad screen for inputting the number of times of multi-layer stitching is displayed by clicking the numeric part.<br>(Only odd numbers can be input as the number of times.) |
| ⑥     |  | 0-5.0 | Stitch length<br>The stitch length for the step that is being edited is displayed.<br>The numeric keypad screen for inputting the stitch length is displayed by clicking the numeric part.  |

\* Be aware that the sewing machine starts when you depress the pedal even when the numeric keypad is displayed on the screen.

## (5) Condensation custom selection screen

The condensation custom selection screen is displayed by pressing  button on the free stitch screen.



| No. | Item  | Range | Explanation   |
|-----|---|-------|---|
| ①   |   |       | The "(6) Condensation custom setting screen"p.34 is displayed by clicking the icon part.  |
| ②   |  | 1-9   | The sewing-start condensation custom pattern number is displayed. The numeric keypad screen for inputting the pattern number is displayed by clicking the numeric part. |
| ③   |  |       | The numeric keypad screen for setting the sewing-end "(6) Condensation custom setting screen"p.34 by clicking the icon part.  |
| ④   |  | 1-9   | The sewing-end condensation custom pattern number is displayed. The numeric keypad screen for inputting the pattern number is displayed by clicking the numeric part.   |
| ⑤   |  |       | The condensation custom is placed in OFF by clicking this item. Then, the "(1) Free stitch screen"p.29 is displayed.  |

\* Be aware that the sewing machine starts when you depress the pedal even when the numeric keypad is displayed on the screen.

## (6) Condensation custom setting screen

The condensation custom screen is displayed by pressing  button on the condensation custom selection screen or the condensation custom selection screen for the polygonal-shape stitch.



Sewing-start condensation custom setting screen

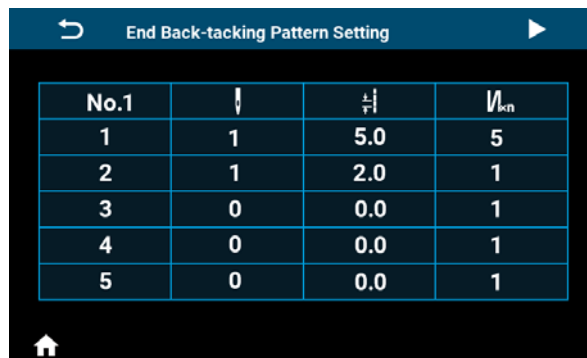

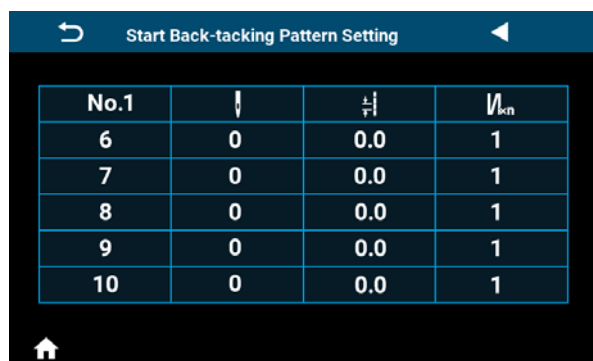

Sewing-end condensation custom setting screen

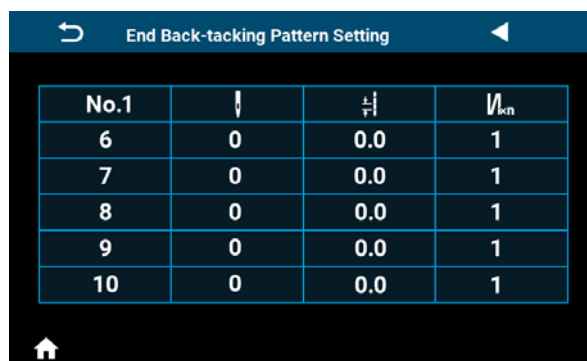

Sewing-start condensation custom setting screen (2)





Sewing-end condensation custom setting screen (2)

| No. | Item  | Setting | Explanation  |
|-----|---|---------|--|
| ①   | <b>No.1</b>   |         | The condensation custom pattern number is displayed.   |
| ②   | <b>1</b>  |         | The step number is displayed.  |
| ③   |  | 1-99    | This item is used to set the number of stitches for the step.<br>The numeric keypad screen for inputting the number of stitches is displayed by clicking this item.<br>If the number of stitches is 0 (zero), the sewing machine will finish sewing at the previous step. The number of stitches for step 1 cannot be set to 0 (zero). |
| ④   |  | 0-5.0   | This item is used to set the stitch length for the step.<br>The numeric keypad screen for inputting the stitch length for the step is displayed by clicking this item.   |
| ⑤   | <b>V<sub>kn</sub></b>   | 1-9     | This item is used to set the number of repetitions of the step.<br>The numeric keypad screen for inputting the number of repetitions of the step is displayed by clicking this item.<br>(Only odd numbers can be input as the number of times.)  |

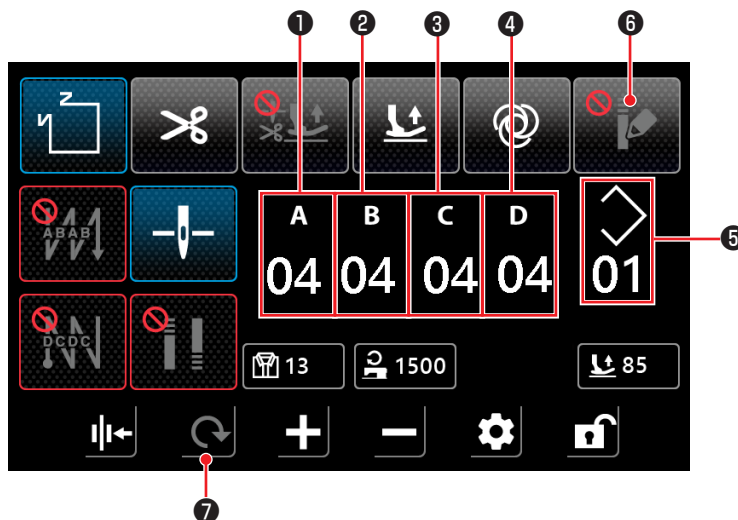
(7) Reverse feed stitch setting screen for the polygonal-shape stitch







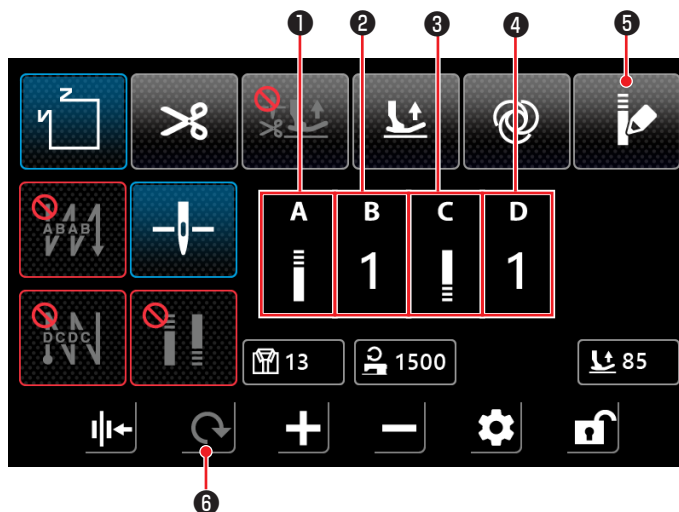

| No. | Item  | Range | Initial value | Explanation   |
|-----|---|-------|---------------|---|
| ①   | <b>A</b><br>04  | 0-15  | 4             | The number of stitches for the sewing-start reverse feed stitching process A is displayed.<br>The numeric keypad screen for inputting the number of stitches is displayed by clicking the numeric part. |
| ②   | <b>B</b><br>04  | 0-15  | 4             | The number of stitches for the sewing-start reverse feed stitching process B is displayed.<br>The numeric keypad screen for inputting the number of stitches is displayed by clicking the numeric part. |
| ③   | <b>C</b><br>04  | 0-15  | 4             | The number of stitches for the sewing-end reverse feed stitching process C is displayed.<br>The numeric keypad screen for inputting the number of stitches is displayed by clicking the numeric part.   |
| ④   | <b>D</b><br>04  | 0-15  | 4             | The number of stitches for the sewing-end reverse feed stitching process D is displayed.<br>The numeric keypad screen for inputting the number of stitches is displayed by clicking the numeric part.   |
| ⑤   |  | 1-10  |               | Polygonal-shape stitching pattern number is displayed.<br>The numeric keypad screen for inputting the pattern number is displayed by clicking the numeric part.   |
| ⑥   |  |       |               | The condensation custom is placed in ON by clicking this item.<br>Then, the "(8) Condensation custom selection screen for the polygonal-shape stitch"p.36 is displayed.                                 |
| ⑦   |  |       |               | The screen returns to the "(3) Polygonal-shape stitch screen"p.31.  |

\* Be aware that the sewing machine starts when you depress the pedal even when the numeric keypad is displayed on the screen.

**(8) Condensation custom selection screen for the polygonal-shape stitch**



| No. | Item  | Range | Explanation   |
|-----|---|-------|---|
| ①   |   |       | The sewing-start <b>"(6) Condensation custom setting screen"p.34</b> is displayed by clicking the icon part.  |
| ②   |  | 1-9   | The sewing-start condensation custom pattern number is displayed. The numeric keypad screen for inputting the pattern number is displayed by clicking the numeric part. |
| ③   |  |       | The numeric keypad screen for setting the sewing-end <b>"(6) Condensation custom setting screen"p.34</b> by clicking the icon part.                                     |
| ④   |  | 1-9   | The sewing-end condensation custom pattern number is displayed. The numeric keypad screen for inputting the pattern number is displayed by clicking the numeric part.   |
| ⑤   |  |       | The condensation custom is placed in OFF by clicking this item. Then, the <b>"(7) Reverse feed stitch setting screen"p.35</b> .   |
| ⑥   |  |       | The screen returns to the <b>"(3) Polygonal-shape stitch screen"p.31</b> .  |

\* Be aware that the sewing machine starts when you depress the pedal even when the numeric keypad is displayed on the screen.

\* The condensation custom pattern is common to the free stitch and polygonal-shape stitch.

## (9) Condensation stitch setting screen

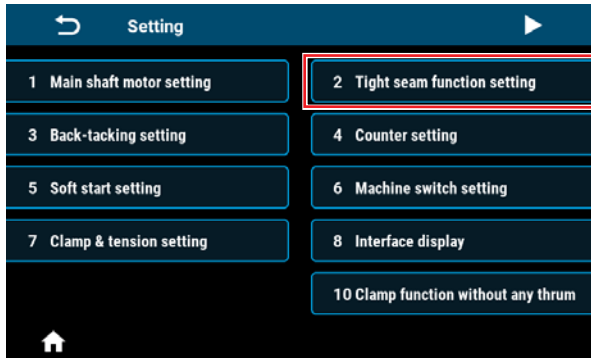

The condensation stitch setting screen is displayed by clicking "2 Tight seam function setting" on the setting screen.

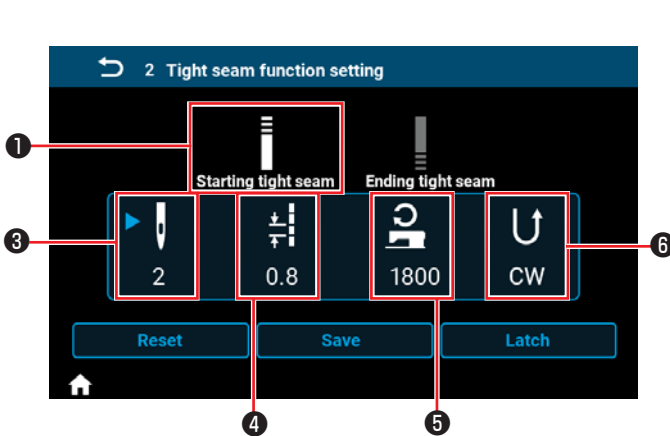

Sewing-start condensation stitch setting screen

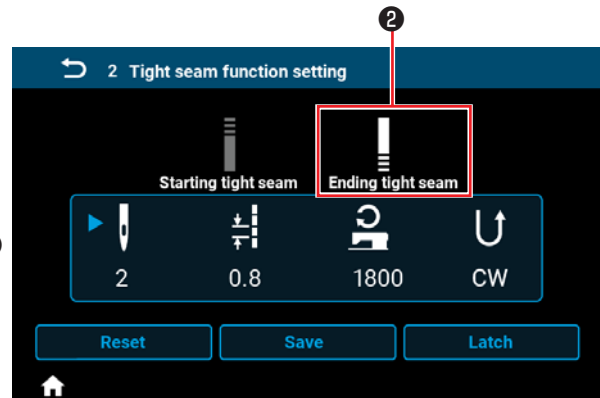

Sewing-end condensation stitch setting screen

| No. | Item | Range    | Explanation   |
|-----|------|----------|---|
| ①   |      |          | The sewing-start condensation stitch is placed in the set state by clicking this item.  |
| ②   |      |          | The sewing-end condensation stitch is placed in the set state by clicking this item.  |
| ③   |      | 0-12     | The number of condensation stitches is displayed.<br>This item is placed in the set state  by clicking the icon part.<br>The numeric keypad screen for inputting the number of condensation stitches is displayed by clicking the numeric part.                   |
| ④   |      | 0.0-5.0  | The condensation stitch length is displayed.<br>This item is placed in the set state  by clicking the icon part.<br>The numeric keypad screen for inputting the condensation stitch length is displayed by clicking the numeric part.                             |
| ⑤   |      | 100-2000 | Sewing speed of the condensation stitch is displayed.<br>This item is placed in the set state  by clicking the icon part.<br>The numeric keypad screen for inputting the condensation stitching speed is displayed by clicking the numeric part.                  |
| ⑥   |      |          | The condensation stitching direction is displayed.<br>This item is placed in the set state  by clicking the icon part.<br>The condensation stitching direction is alternately changed over between CW (clockwise direction) and CCW (counterclockwise direction). |

(10) Screen for setting the number of stitches per inch

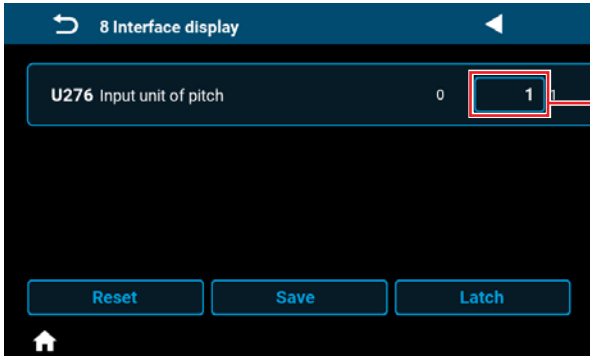

The stitch length can be set using the number of stitches per inch by setting "U276 Input unit of pitch" to ①.

\* Refer to "Table 1: Pitch correspondence table" and "Table 2: Stitch per inch correspondence table" p.39 for settable values.

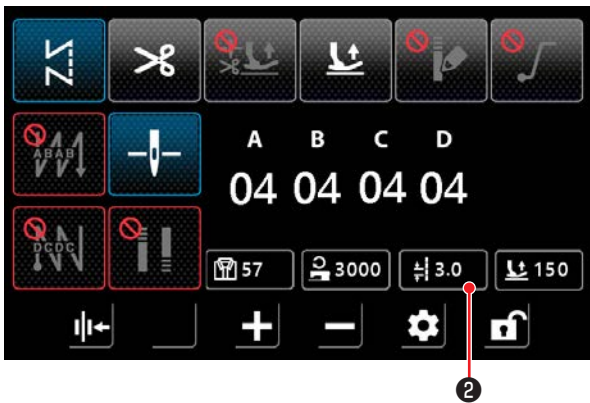

1) In the case the function of setting the number of stitches per inch is enabled, the screen for setting the number of stitches per inch is displayed by pressing the stitch length button ②.

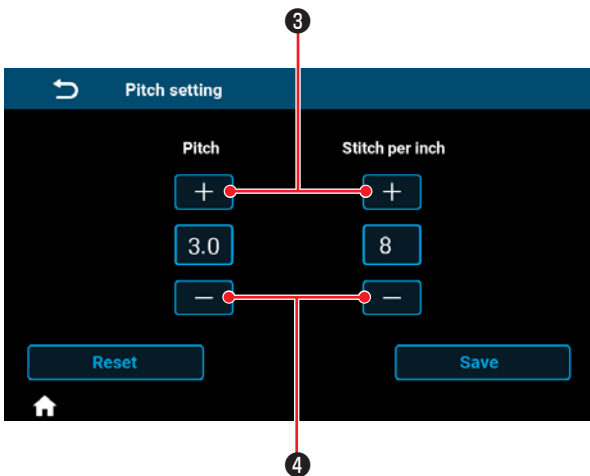

2) The stitch length is set to the value that corresponds to the number of stitches per inch by inputting the number of stitches per inch with the + and - buttons.

Table 1: Pitch correspondence table

| Pitch | Stitch per inch |
|-------|-----------------|
| 0.0   | 100             |
| 0.1   | 100             |
| 0.2   | 100             |
| 0.3   | 85              |
| 0.4   | 64              |
| 0.5   | 51              |
| 0.6   | 42              |
| 0.7   | 36              |
| 0.8   | 32              |
| 0.9   | 28              |
| 1.0   | 25              |
| 1.1   | 23              |
| 1.2   | 21              |
| 1.3   | 20              |
| 1.4   | 18              |
| 1.5   | 17              |
| 1.6   | 16              |
| 1.7   | 15              |
| 1.8   | 14              |
| 1.9   | 13              |
| 2.0   | 13              |
| 2.1   | 12              |
| 2.2   | 12              |
| 2.3   | 11              |
| 2.4   | 11              |
| 2.5   | 10              |
| 2.6   | 10              |
| 2.7   | 9               |
| 2.8   | 9               |
| 2.9   | 9               |
| 3.0   | 8               |
| 3.1   | 8               |
| 3.2   | 8               |
| 3.3   | 8               |
| 3.4   | 7               |
| 3.5   | 7               |
| 3.6   | 7               |
| 3.7   | 7               |
| 3.8   | 7               |
| 3.9   | 7               |
| 4.0   | 6               |
| 4.1   | 6               |
| 4.2   | 6               |
| 4.3   | 6               |
| 4.4   | 6               |
| 4.5   | 6               |
| 4.6   | 6               |
| 4.7   | 5               |
| 4.8   | 5               |
| 4.9   | 5               |
| 5.0   | 5               |

Table 2: Stitch per inch correspondence table

| Stitch per inch | Pitch | Stitch per inch | Pitch |
|-----------------|-------|-----------------|-------|
| 0               | 0.0   | 55              | 0.5   |
| 1               | 5.0   | 56              | 0.5   |
| 2               | 5.0   | 57              | 0.4   |
| 3               | 5.0   | 58              | 0.4   |
| 4               | 5.0   | 59              | 0.4   |
| 5               | 5.0   | 60              | 0.4   |
| 6               | 4.2   | 61              | 0.4   |
| 7               | 3.6   | 62              | 0.4   |
| 8               | 3.2   | 63              | 0.4   |
| 9               | 2.8   | 64              | 0.4   |
| 10              | 2.5   | 65              | 0.4   |
| 11              | 2.3   | 66              | 0.4   |
| 12              | 2.1   | 67              | 0.4   |
| 13              | 2.0   | 68              | 0.4   |
| 14              | 1.8   | 69              | 0.4   |
| 15              | 1.7   | 70              | 0.4   |
| 16              | 1.6   | 71              | 0.4   |
| 17              | 1.5   | 72              | 0.4   |
| 18              | 1.4   | 73              | 0.3   |
| 19              | 1.3   | 74              | 0.3   |
| 20              | 1.3   | 75              | 0.3   |
| 21              | 1.2   | 76              | 0.3   |
| 22              | 1.2   | 77              | 0.3   |
| 23              | 1.1   | 78              | 0.3   |
| 24              | 1.1   | 79              | 0.3   |
| 25              | 1.0   | 80              | 0.3   |
| 26              | 1.0   | 81              | 0.3   |
| 27              | 0.9   | 82              | 0.3   |
| 28              | 0.9   | 83              | 0.3   |
| 29              | 0.9   | 84              | 0.3   |
| 30              | 0.8   | 85              | 0.3   |
| 31              | 0.8   | 86              | 0.3   |
| 32              | 0.8   | 87              | 0.3   |
| 33              | 0.8   | 88              | 0.3   |
| 34              | 0.7   | 89              | 0.3   |
| 35              | 0.7   | 90              | 0.3   |
| 36              | 0.7   | 91              | 0.3   |
| 37              | 0.7   | 92              | 0.3   |
| 38              | 0.7   | 93              | 0.3   |
| 39              | 0.7   | 94              | 0.3   |
| 40              | 0.6   | 95              | 0.3   |
| 41              | 0.6   | 96              | 0.3   |
| 42              | 0.6   | 97              | 0.3   |
| 43              | 0.6   | 98              | 0.3   |
| 44              | 0.6   | 99              | 0.3   |
| 45              | 0.6   | 100             | 0.3   |
| 46              | 0.6   |                 |       |
| 47              | 0.5   |                 |       |
| 48              | 0.5   |                 |       |
| 49              | 0.5   |                 |       |
| 50              | 0.5   |                 |       |
| 51              | 0.5   |                 |       |
| 52              | 0.5   |                 |       |
| 53              | 0.5   |                 |       |
| 54              | 0.5   |                 |       |

## (11) How to use the counter

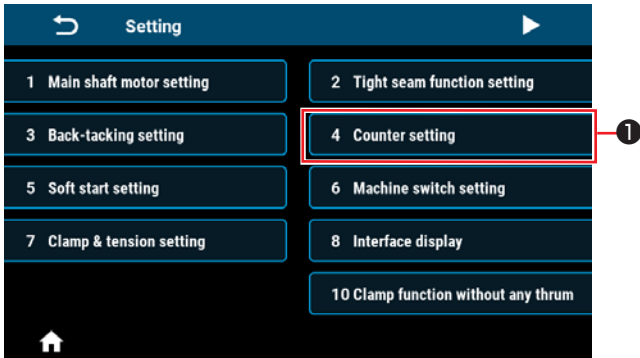

- 1) The counter setting screen is displayed by clicking "4 Counter setting" ① on the setting screen.

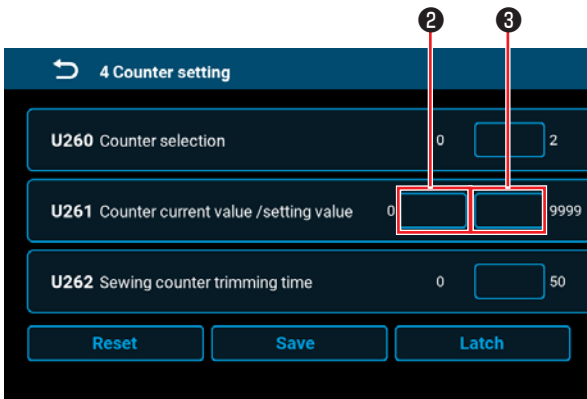







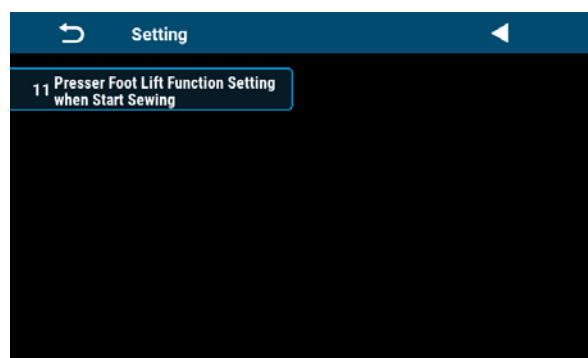
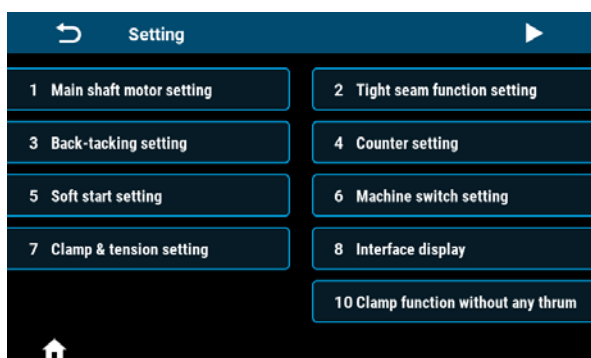

- 2) Set the counter set value in ③ of U261 on the counter setting screen. The counter setting screen is displayed when the current value ② on the counter reaches the set value when the sewing machine carries out sewing while the sewing screen is displayed.  
Set the counting method with U260 and U262. (Refer to the setting list for details.)
- 3) If you want to clear the current value on the counter, double click the sewing count value button  on the sewing screen.

## 5-3. Function setting list

### (1) User level memory switch



| No. | Setting items  |
|-----|--|
| 1   | Main shaft motor setting                             |
| 2   | Tight seam function setting                          |
| 3   | Back-tacking setting                                 |
| 4   | Counter setting                                      |
| 5   | Soft start setting                                   |
| 6   | Machine switch setting                               |
| 7   | Clamp & tension setting                              |
| 8   | Interface display                                    |
| 10  | Clamp function without any thrum                     |
| 11  | Presser Foot Lift Function Setting when Start Sewing |

| No.                            | Items  | Range      | Default |        | Description   |
|--------------------------------|--|------------|---------|--------|---|
|                                |  |            | M type  | H type |   |
| 1. Main shaft motor setting    |  |            |         |        |   |
| 1-U056                         | Needles goes up automatically as power turned on                                     | OFF/<br>ON | ON      | ON     |   |
| 1-U060                         | Origin retrieve when power is turned on  | OFF/<br>ON | OFF     | OFF    | OFF : After turning on the power, you cannot sew unless you depress the pedal once.<br>ON : After turning on the power, make it ready for sewing immediately.<br>⇒ When this item is set to ON, the sewing machine shifts to the origin retrieval after turning the power ON. Take care not to place your hands or the fabric around the presser foot and pulley. |
| 1-U301                         | Main shaft motor maximum speed limit<br>(Maximum value varies with the machine head) | 0-MAX      | 4000    | 4000   | M type : MAX 5000<br>H type : MAX 4000  |
| 2. Tight seam function setting |  |            |         |        |   |
| 2-1. Starting tight seam       |  |            |         |        |   |
|                                |   | 0-12       | 2       | 2      | Condensation stitching  |
|                                |   | 0-5.0      | 0.5     | 0.8    | Stitches length Unit: mm  |
|                                |   | 100-2000   | 1800    | 1800   | Sewing speed  |
|                                |   | CW/<br>CCW | CW      | CW     | Direction   |
| 2-2. Ending tight seam         |  |            |         |        |   |
|                                |   | 0-12       | 2       | 2      | Condensation stitching  |
|                                |   | 0-5.0      | 0.5     | 0.8    | Stitches length Unit: mm  |
|                                |   | 100-2000   | 1800    | 1800   | Sewing speed  |
|                                |   | CW/<br>CCW | CW      | CW     | Direction   |
| 3. Back-tacking setting        |  |            |         |        |   |
| 3-U004                         | Start back-tacking speed   | 200-3200   | 2000    | 2000   |   |

| No.                   | Items  | Range    | Default |        | Description   |
|-----------------------|--|----------|---------|--------|---|
|                       |  |          | M type  | H type |   |
| 3-U005                | End back-tacking speed   | 200-3200 | 2000    | 2000   |   |
| 3-U010                | The constant-stitch whether can execute end back-tacking sewing function selection | OFF/ON   | ON      | ON     |   |
| 3-U012                | Star back-tacking mode selection   | OFF/ON   | ON      | ON     |   |
| 3-U013                | Mode selection at the end of start back-tacking                                    | OFF/ON   | ON      | ON     |   |
| 3-U018                | Start back-tacking stitch compensation 1   | 0-200    | 160     | 160    |   |
| 3-U019                | Start back-tacking stitch compensation 2   | 0-200    | 160     | 160    |   |
| 3-U025                | End back-tacking stitch compensation 3   | 0-200    | 160     | 160    |   |
| 3-U026                | End back-tacking stitch compensation 4   | 0-200    | 160     | 160    |   |
| 3-U032                | Back-tacking stitch compensation 5   | 0-200    | 160     | 160    |   |
| 3-U033                | Back-tacking stitch compensation 6   | 0-200    | 160     | 160    |   |
| 3-U237                | Start back-tacking stitch compensation 11  | 0-200    | 160     | 160    |   |
| 3-U238                | Start back-tacking stitch compensation 12  | 0-200    | 160     | 160    |   |
| 3-U239                | End back-tacking stitch compensation 13  | 0-200    | 160     | 160    |   |
| 3-U240                | End back-tacking stitch compensation 14  | 0-200    | 160     | 160    |   |
| 3-U241                | Back-tacking stitch compensation 15  | 0-200    | 160     | 160    |   |
| 3-U242                | Back-tacking stitch compensation 16  | 0-200    | 160     | 160    |   |
| 3-U235                | Pattern sewing compensation 1  | 0-200    | 160     | 160    |   |
| 3-U236                | Pattern sewing compensation 2  | 0-200    | 160     | 160    |   |
| 4. Counter setting    |  |          |         |        |   |
| 4-U260                | Counter selection  | 0-2      | 1       | 1      | 0: Counter does not count<br>1: Count up<br>2: Count-down |
| 4-U261                | Counter current value /setting value   | 0-9999   | 0/9999  | 0/9999 |   |
| 4-U262                | Sewing counter trimming time   | 0-50     | 1       | 1      |   |
| 5. Soft start setting |  |          |         |        |   |

| No.                           | Items   | Range        | Default |        | Description  |
|-------------------------------|---|--------------|---------|--------|--|
|                               |   |              | M type  | H type |  |
| 5-U014                        | Soft start switch   | ON/<br>OFF   | OFF     | OFF    |  |
| 5-U008                        | Stitch numbers for soft start   | 1-15         | 2       | 2      |  |
| 5-U090                        | Soft start first stitch speed   | 200-<br>1500 | 400     | 400    |  |
| 5-U091                        | Soft start second stitch speed  | 200-<br>1500 | 1000    | 1000   |  |
| 5-U007                        | Soft start speed after second stitch  | 200-<br>1500 | 1500    | 1500   |  |
| 6. Machine switch setting     |   |              |         |        |  |
| 6-U015                        | Manual switch A setting   | 0-7          | 5       | 5      | 0: OFF<br>1: Half stitch<br>2: One stitch<br>3: Continuous half stitch<br>4: Continuous one stitch<br>5: Back-tacking when machine stop or pause<br>6: Tight seam function<br>7: Count number of pieces sewn |
| 6-U174                        | Manual switch B setting   | 0-7          | 3       | 3      | 0: OFF<br>1: Half stitch<br>2: One stitch<br>3: Continuous half stitch<br>4: Continuous one stitch<br>5: Back-tacking when machine stop or pause<br>6: Tight seam function<br>7: Count number of pieces sewn |
| 6-U118                        | Manual back-tacking function selection under pattern sewing                             | 0-1          | 1       | 1      |  |
| 7. Clamping & tension setting |   |              |         |        |  |
| 7-U103                        | Tension strength setting  | 1-80         | 50      | 50     |  |
| 7-U035                        | With or without tension while foot lifting action                                       | ON/<br>OFF   | OFF     | OFF    |  |
| 7-U037                        | Wiping / clamping strength setting  | 0-11         | 9       | 9      | 0: OFF<br>1: Wiping function<br>2: to 11: Clamping function, the higher the value, the stronger the action.  |
| 7-U036                        | Tension function switch   | ON/<br>OFF   | ON      | ON     |  |
| 7-U030                        | The foot lift height of thread tension release start action when knee-control foot lift | 0-300        | 75      | 75     |  |
| 7-U031                        | Thread tension release function switch when knee-control foot lift                      | ON/<br>OFF   | OFF     | OFF    |  |

| No.  | Items   | Range             | Default |         | Description  |
|--|---|-------------------|---------|---------|--|
|  |   |                   | M type  | H type  |  |
| 8. Interface display                                     |   |                   |         |         |  |
| 8-U270   | Brightness  | 10-100            | 80      | 80      |  |
| 8-U271   | Main interface locked automatically                                     | 0-900             | 60      | 60      |  |
| 8-U272   | Restore factory defaults  |                   |         |         |  |
| 8-U273   | Language  | Chinese / English | Chinese | Chinese |  |
| 8-U275   | Data output to JaNets   | 0-3               | 0       | 0       | This item is used to set data output to JaNets.<br>0: Data is not output to JaNets<br>1 -: Data is output to JaNets  |
| 8-U276   | Input unit of pitch   | 0-1               | 0       | 0       | 0 : mm 1 : inch  |
| 10. Clamp function without any thrum                     |   |                   |         |         |  |
| 10-U111  | Clamp function without any thrum switch                                 | ON/OFF            | OFF     | OFF     |  |
| 10-U279  | Cloth puller function selection   | 0-3               | 0       | 0       | 0: Pre-emption function OFF<br>1: Output from bird's nest prevention port1<br>2: Output from bird's nest prevention port2<br>3: Output from bird's nest prevention port3 |
| 11. Presser Foot Lift Function Setting when Start Sewing |   |                   |         |         |  |
| 11-U201  | Presser Foot Lift Function Setting Switch when Start Sewing             | ON/OFF            | OFF     | OFF     |  |
| 11-U202  | Presser Foot Lift Function Setting Start Output Angle when Start Sewing | 1-359             | 1       | 1       |  |
| 11-U203  | Presser Foot Lift Function Setting End Output Angle when Start Sewing   | 1-359             | 80      | 80      |  |
| 11-U204  | Presser Foot Lift Output Signal when Start Sewing                       | 0-100             | 30      | 30      |  |

## 5-4. List of error codes

| Error codes | Description  | Measures   |
|-------------|--|--|
| E01         | High-voltage   | 1. Whether the grid voltage is higher than AC300V.   |
|             |  | 2. If it is self-generated power supply, please reduce the generator power.  |
|             |  | 3. If it still does not work normally, please replace the control box and notify the after-sales service.  |
| E02         | Low-voltage  | 1. Whether the grid voltage is lower than AC160V.  |
|             |  | 2. If it is self-generated power supply, please increase the generator power.  |
|             |  | 3. If it still does not work normally, please replace the control box and notify the after-sales service.  |
| E03         | CPU communication fault  | 1. Turn off the system power and check whether the connection of the display screen is loose or disconnected, restart the system after returning it to normal.   |
|             |  | 2. Turn off the system power, remove the control box and only plug in the power cord to power on, whether alarm E05, if it still alarms E03, replace the control box and notify the after-sales service. |
| E05         | Pedal signal abnormal  | 1. Check whether the pedal connector is loose or fall off, and restart the system after returning it to normal.  |
|             |  | 2. If it still does not work normally, please replace the control box or speed controller and notify the after-sales service.  |
| E07         | Main shaft motor locked-rotor  | 1. Turn off the power and check whether the handwheel can be turned smoothly (turn the handwheel by hand), if it cannot be turned, please check the machine.   |
|             |  | 2. Turn off the power, check whether the motor power connector is loose, plug it in and restart it.  |
|             |  | 3. Check whether the upper needle stop position is correct, if not, please adjust the upper positioning position.  |
|             |  | 4. If it still does not work normally, please replace the control box or main shaft motor and notify the after-sales service.  |
| E09<br>E11  | The upper positioning signal of main shaft motor encoder is abnormal | 1. Turn off the system power, check whether main shaft motor encoder connector is loose or fall off, restore it to normal and restart the system.  |
|             |  | 2. Check whether the motor zero point correction setting is correct, reset the motor zero point correction.  |
|             |  | 3. Whether there is oil on the encoder code plate, please clean it if there is any.  |
|             |  | 4. If it still does not work normally, please replace the control box or main shaft motor and notify the after-sales service.  |

| Error codes | Description                                 | Measures   |
|-------------|---|--|
| E10         | Electromagnet over-current                  | 1. Unplug the solenoid connector, if alarm E10, replace the control box and notify the after-sales service.  |
|             |   | 2. If there is no alarm after removing the solenoid connector, please plug it back in.   |
|             |   | 1) Step on the front pedal to let the sewing machine perform thread clamping. If alarms, please turn off the thread clamping function and restart the electronic control box, and step forward again, if there is no alarm, replace the clamber. |
|             |   | 2) Step on the front pedal to let the sewing machine perform thread clamping. If there is no alarm, please back step pedal to trim. If it alarms, please replace the thread trimming solenoid  |
| E14         | Main shaft motor encoder signal is abnormal | 1 Turn off the system power, check whether the main shaft motor encoder connector is loose or fall off, restore it to normal and restart the system.   |
|             |   | 2. Check whether the grating is installed correctly (whether the grating screws are tightened and whether the grating is in the center of the encoder).  |
|             |   | 3. Check whether there is oil on the encoder code plate, if there is, please clean it up, and restart the system after recovery.   |
|             |   | 4. If it still does not work normally, please replace the control box or main shaft motor and notify the after-sales service.  |
| E15         | Main shaft motor drive overcurrent          | 1. Please check whether the motor power cord has bad contact.  |
|             |   | 2. Please check whether the motor power cord is crushed.   |
|             |   | 3. Please replace the control box or main shaft motor and notify the after-sales service.  |
| E17         | Machine overturned                          | 1. Turn off the system power and check if the machine is overturned.   |
|             |   | 2. Check whether the machine protection switch detection setting is correct.   |
|             |   | 3. If it still does not work normally, please replace the control box or panel and notify the after-sales service.   |
| E20         | Main shaft motor failed to start            | 1. Turn off the system power, check whether main shaft motor power cord connector and encoder connector are loose or fall off, restore them to normal and restart the system.  |
|             |   | 2. Check whether the motor zero point correction setting is correct, reset the motor zero point correction.  |
|             |   | 3. If it still does not work normally, please replace the control box or main shaft motor and notify the after-sales service.  |
| E46         | Watchdog timer reset failure                | 1. Turn OFF the power to the system and re-turn it ON. Then, check whether the system has returned to normal.  |
|             |   | 2. If the system still fails to operate normally, change the electrical control box with a new one and notify the After-Sales Service Department about it.   |
| E60         | Brake resistor is abnormal                  | 1. Shut down the system, check brake resistor for looseness or damage.   |
|             |   | 2. Shut down the system, replace brake resistor.   |
|             |   | 3. If it still does not work normally, please replace the control box and inform the after-sales service.  |
| E70         | System error                                | Please cut off the power, and then turn on the power again.  |

| Error codes | Description   | Measures   |
|-------------|---|--|
| E80         | Abnormal communication between main chip and drive chip                       | Please replace the control box and notify the after-sales service.   |
| E82         | Back-tacking stepper motor overcurrent  | <ol style="list-style-type: none"> <li>1. Turn off the system power and observe whether back-tacking stepper motor is stuck. If it is stuck, remove the mechanical failure of the machine first. If it is normal, check whether connector of backtacking stepper motor is loose or fall off, restore it to normal and restart the system.</li> <li>2. If it still does not work normally, please replace the control box or back-tacking stepper motor and notify the after-sales service.</li> </ol>  |
| E84         | The upper positioning signal of backtacking stepper motor encoder is abnormal | <ol style="list-style-type: none"> <li>1. Turn off the system power and observe whether back-tacking stepper motor is stuck. If it is stuck, remove the mechanical failure of the machine first. If it is normal, check whether the encoder connector of back-tacking stepper motor is loose or fall off, and restart the system after returning it to normal.</li> <li>2. Check whether the grating is installed correctly (whether the grating screws are fastened and whether the grating is in the center of the encoder).</li> <li>3. Check if there is oil on the grating code plate, if so, please clean it up, and restart the system after restoration.</li> <li>4. If it still does not work normally, please replace the control box or back-tacking stepper motor and notify the after-sales service.</li> </ol> |
| E85         | Back-tacking motor encoder signal is abnormal                                 | <ol style="list-style-type: none"> <li>1. Turn off the power of the system, check whether the encoder connector of back-tacking stepper motor is loose or fall off, restore it to normal and restart the system.</li> <li>2. Check whether the grating is installed correctly (whether the grating screws are fastened and whether the grating is in the center of the encoder)</li> <li>3. Check if there is oil on the grating code plate, if so, please clean it up, and restart the system after restoration</li> <li>4. If it still does not work normally, please replace the control box or back-tacking stepper motor and notify the after-sales service.</li> </ol>   |
| E86         | Back-tacking stepper motor failed to start                                    | <ol style="list-style-type: none"> <li>1. Turn off the power of the system, check whether the power cord connector of back-tacking stepper motor and the encoder connector are loose or fall off, restore them to normal and restart the system.</li> <li>2. Check whether the grating is installed correctly (whether the grating screws are fastened and whether the grating is in the center of the encoder);</li> <li>3. Check if there is oil on the grating code plate, if so, please clean it up, and restart the system after restoration;</li> <li>4. If it still does not work normally, please replace the control box or back-tacking stepper motor and notify the after-sales service.</li> </ol>   |
| E87         | Back-tacking stepper motor locked-rotor                                       | <ol style="list-style-type: none"> <li>1. Turn off the system power and observe whether back-tacking stepper motor is stuck. If it is stuck, remove the mechanical failure of the machine first. If it is normal, check whether the power cord connector of back-tacking motor and the encoder connector are loose or fall off, restore them to normal and restart the system.</li> <li>2. If it still does not work normally, please replace the control box or back-tacking stepper motor and notify the after-sales service.</li> </ol>   |

| Error codes | Description   | Measures   |
|-------------|---|--|
| E92         | Trimming (presser foot) stepper motor overcurrent   | 1. Turn off the system power and observe whether trimming (presser foot) stepper motor is stuck. If it is stuck, remove the mechanical failure of the machine first. If it is normal, check if trimming (presser foot) stepper motor connector is loose or fall off, restore it to normal and restart the system.  |
|             |   | 2. If it still does not work normally, please replace the control box or trimming (presser foot) stepper motor and notify the after-sales service.   |
| E94         | The upper positioning signal of trimming (presser foot) stepper motor encoder is abnormal | 1. Turn off the system power and observe whether trimming (presser foot) stepper motor is stuck. If it is stuck, remove the mechanical failure of the machine first. If it is normal, check whether trimming (presser foot) stepper motor encoder connector is loose or falling off, and whether there is oil on the encoder code plate. If there is, please clean it up, restore it to normal and restart the system. |
|             |   | 2. If it still does not work normally, please replace the control box or trimming (presser foot) stepper motor and notify the after-sales service.   |
| E95         | Trimming (presser foot) stepper motor encoder signal is abnormal                          | 1. Turn off the system power, check if the thread trimming (presser foot) stepper motor encoder connector is loose or fall off, restore it to normal and restart the system.   |
|             |   | 2. If it still does not work normally, please replace the control box or the thread trimming (presser foot) stepper motor and notify the after-sales service.  |
| E96         | Trimming (presser foot) stepper motor failed to start                                     | 1. Turn off the power of the system, check whether the thread trimming (presser foot) stepper motor power cord connector and encoder connector are loose or fall off, and restart the system after returning it to normal.   |
|             |   | 2. If it still does not work normally, please replace the control box or the thread trimming (presser foot) stepper motor and notify the after-sales service.  |
| E97         | Trimming (presser foot) stepper motor locked-rotor  | 1. Turn off the system power and observe whether the thread trimmer (presser foot) stepper motor is stuck. If it is stuck, remove the mechanical failure of the machine first. If it is normal, check whether the thread trimming (presser foot) stepper motor power cord connector and encoder connector are loose or fall off, restore them to normal and restart the system.  |
|             |   | 2. If it still does not work normally, please replace the control box or the thread trimming (presser foot) stepper motor and notify the after-sales service.  |
| E100        | Main shaft motor overload   | 1. Turn OFF the power to the system. Check whether the mechanical load is excessive. Then, reset the system to the normal state, and re-turn ON the system.  |
|             |   | 2. Check whether the spindle-motor zero point correction is correct. Then, reset the zero point correction of the motor.   |
|             |   | 3. If the system still fails to operate normally, change the main shaft motor and the electrical control box with new ones and contact the After-Sales Service Department.   |

| Error codes | Description   | Measures  |
|-------------|---|---|
| E110        | When the power to the system is turned ON, reception of the operation panel data by the main PCB is abnormal. | <ol style="list-style-type: none"> <li>1. Turn OFF the power to the system. Check whether the display cable is loose or disconnected. Then, fix the cable back to its normal state and re-turn ON the system.</li> <li>2. If the system still fails to operate normally, change the operation panel and the electrical control box with new ones and notify the After-Sales Service Department about it.</li> </ol> |
| PEDAL       | Initial operation has not yet been completed.   | Depress the back part of the pedal to carry out the initial operation.  |
| P_OFF       | Turn OFF the power switch.  | Turn the power OFF. Then, wait until the screen disappears and re-turn the power ON.  |